

OVERVIEW: ELECTRICALLY-ACTUATED AIR ATOMIZING NOZZLES

- Electrically-actuated nozzles provide the fastest cycling of any automatic nozzles – up to 10,000 cycles per minute
- Compressed air is used as the force for atomization, producing the smallest drop sizes and lowest possible flow rates
- Hundreds of air atomizing set-ups are available for a wide variety of spray patterns and flow rates
- Precision Spray Control using an AutoJet® Spray Controller ensures consistent flow rates at varying line speeds
- Many options are available for convenient mounting, clean-out needles, food grade materials of construction and more

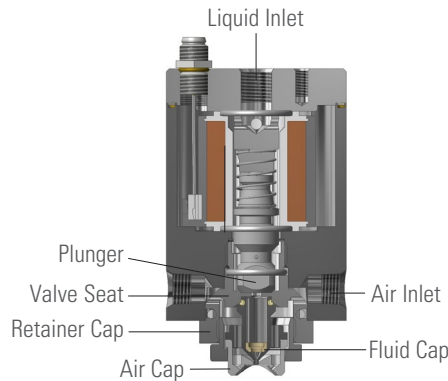

AA10000JAU Nozzle

The compact design and simple mounting options for PulsaJet® nozzles enable them to be easily integrated into most production areas. Wear parts for all PulsaJet nozzles are easily accessible to minimize routine maintenance time.

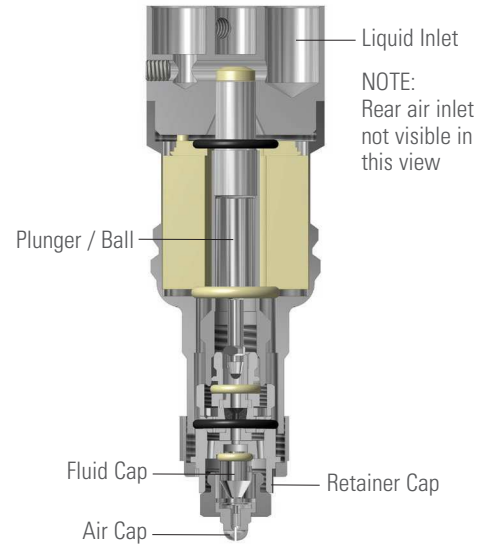

AA28JJAU Nozzle

AA28JJAU nozzles feature a removable fluid module which contains all fluid handling parts and can be replaced without disturbing the mounting or electrical connections.

QUICK REFERENCE GUIDE

Product Number	Connection Size (in.)	Max Liquid Pressure	Power	Max Air Pressure	Max Flow	Max Temp (liquid)	Max Speed	Spray Set-Ups
AA10000JJAU	1/8 NPT or BSPT (air and liquid)	100 psi (7 bar) 250 psi (17 bar) (w/ AutoJet 2008+ spray controller)	24 VDC, (0.36 Amp)	100 psi (7 bar)	0.16 gpm (0.61 lpm)	200°F (93°C)	10,000 cpm	JJ set-ups (page D33)
AA10000JAU-10	1/8 NPT or BSPT (air and liquid)	100 psi (7 bar)	24 VDC (1.05 Amp)	100 psi (7 bar)	0.75 gpm (2.84 lpm)	200°F (93°C)	5000 cpm	Threadless 1/4J set-ups (page D22)
AA28JJAU-49815	1/8 NPT (air and liquid)	125 psi (8.6 bar)	24 VDC (0.50 Amp)	100 psi (7 bar)	0.42 gpm (1.62 lpm)	150°F (66°C)	2000 cpm	JJ set-ups (page D33)
AA29JAUCO	1/8 NPT or BSPT (air and liquid)	60 psi (4.0 bar)	24 VDC (0.75 Amp)	100 psi (7 bar)	0.75 gpm (2.84 lpm)	150°F (66°C)	1000 cpm	Threadless 1/4J set-ups (page D22)

ELECTRICALLY-ACTUATED AIR ATOMIZING PULSAJET® NOZZLE OPTIONS

AA10000JJAU

- Rear liquid inlet; side air inlet
- Flow rates up to 0.16 gpm (0.61 lpm)
- Stainless steel, PPS and PEEK construction with Viton® or EPDM seals
- All wear parts accessible from the front of the nozzle without disturbing mounting and air/liquid/electrical connections
- For use with standard 1/8JJ air caps and 1/8JJ fluid caps (maximum size 2850)

**AA10000JAU-10**

- Rear liquid inlet; side air inlet
- Flow rates up to 0.75 gpm (2.84 lpm)
- Stainless steel, PPS and PEEK construction with Viton or EPDM seals
- All wear parts accessible from the front of the nozzle without disturbing mounting and air/liquid/electrical connections
- For use with standard 1/4J air caps and threadless 1/4J fluid caps (maximum size 80100)



OTHER ELECTRICALLY-ACTUATED AIR ATOMIZING NOZZLE OPTIONS

AA28JJAU-49815

- Flow rates up to 0.42 gpm (1.62 lpm)
- Compact design features rear air and liquid inlets to minimize nozzle profile
- Fluid modules available for in-line, 45° or 75° spray direction
- Stainless steel, carbide and nylon construction with Viton or EPDM seals
- Fluid re-circulation possible
- For use with standard 1/8JJ air caps and 1/8JJ fluid caps (maximum size 2850)

**AA29JAUCO**

- Flow rates up to 0.75 gpm (2.84 lpm)
- Rear air and liquid inlets to minimize nozzle profile
- Additional side liquid inlet available for liquid recirculation
- Stainless steel, PTFE and PPS construction with Viton seals
- Clean-out needle standard for all fluid cap sizes
- For use with standard 1/4J air caps and threadless 1/4J fluid caps (maximum size 80100)

**PLACING YOUR ORDER**

Call 1.630.665.5000 for application assistance
or to place an order.

FOR DETAILED SPRAY TIP PERFORMANCE DATA
SEE SECTION D