



# 54200 VMAU Lab Coater

## NEW Variable Automatic Lab Coater Nozzle

Features a compact design and simple assembly suited to your R&D/laboratory scale spray applications.



### Specifications

Incorporates independent controls of liquid, atomizing air and fan air for fine tuning of spray capacity, droplet size, and spray patterns

Liquid shut-off seal on the needle tip allows easy removal for cleaning maintenance

Polished 316L stainless steel body and push-connect tube fittings

O-ring sealed air cap on the fluid tip for positive alignment and sealing

VMAU and 53000 "J" type set-up versions available  
(VMAU version shown above)

Same size air cap and fluid tip as standard VMAU automatic spray nozzle

Anti-bearding spray set-ups

Compact modular body and threadless fluid tip design

FDA compliant seal and material options

Optional mounting available

### Benefits

- Simplifies your scale-up
- Provides even spray distribution and minimizes overspray
- Anti-bearding design significantly reduces bearding and clogging
- Increases throughput with improved spray and product quality
- Reduces maintenance and production costs
- Minimizes cleaning and maintenance downtime
- 316L stainless steel nozzle and fittings for corrosion resistance
- Disassembles quickly

### Typical Applications



Pharmaceutical Coating  
Moistening  
Nutraceuticals

# 54200 VMAU Lab Coater



## Dimensions

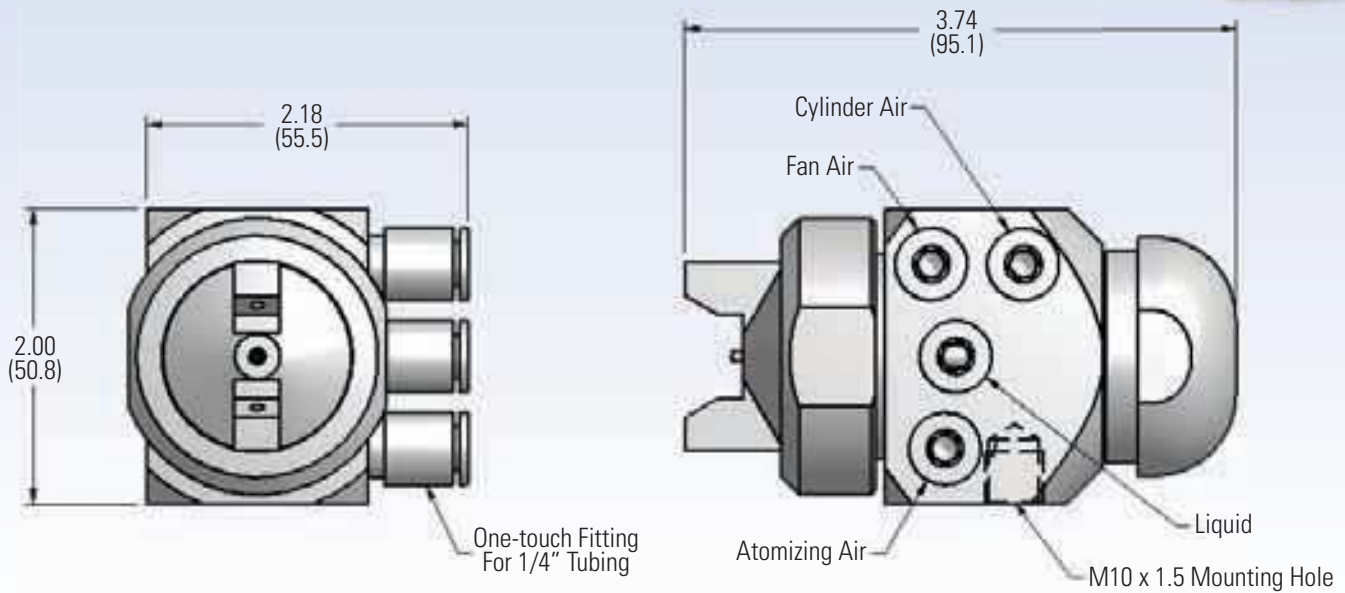

## Easier Scale-Up and Validation

The spray set-up (fluid tip and air cap) on the 54200 VMAU Lab Coater is the same size used for the 54000 Modular Air Atomizing Manifold and VMAU/53000 "J" type set-up automatic spray nozzles, making it simple to scale up from smaller lab scale applications to full production.

## Reduce Maintenance Downtime with Simple Disassembly

The 54200's actuator has the liquid shut-off seal on the needle tip, allowing easy removal for cleaning and maintenance. Simply remove the actuator cylinder cap by hand and push the needle assembly out. The seals come right out with the assembly; there are no packing screws or retainers that require tools for removal.



**Spraying Systems Co.**  
Experts in Spray Technology

North Avenue and Schmale Road, P.O. Box 7900, Wheaton, IL 60187-7901 USA

Tel: 1.800.95.SPRAY    Intl. Tel: 1.630.665.5000  
Fax: 1.888.95.SPRAY    Intl. Fax: 1.630.260.0842

www.spray.com



Spray  
Nozzles



Spray  
Control



Spray  
Analysis



Spray  
Fabrication



Bulletin No. 672    Printed in the U.S.A.    ©Spraying Systems Co. 2010