

OVERVIEW: AIR-ACTUATED HYDRAULIC NOZZLES

- A compressed air inlet on the nozzle body is used to control air cylinder operation for accurate intermittent spraying up to 180 cycles per minute
- Lightweight nozzles use only liquid pressure as the force for atomization
- A variety of nozzle bodies are available for convenient mounting and positioning
- Models are available with extensions and with a recirculating option to optimize performance
- UniJet® spray tips provide a wide variety of spray patterns and flow rates at liquid pressures up to 4000 psi (275 bar)

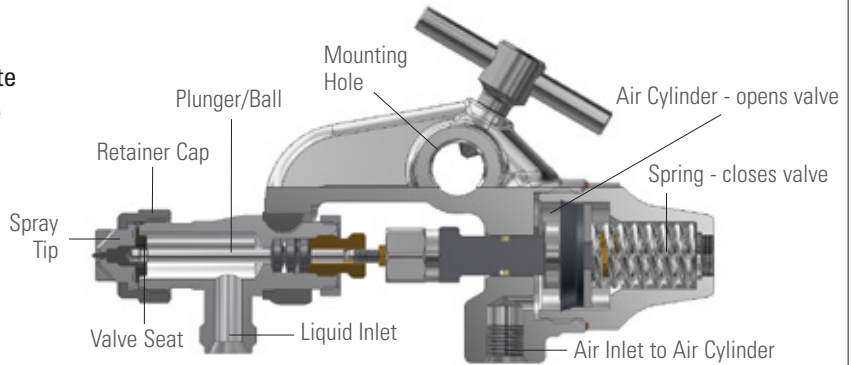

AA22AUH Nozzle

AA22AUH nozzles provide controlled intermittent liquid spray using only hydraulic pressure as the force for atomization. An internal air cylinder automatically interrupts the liquid flow at any desired frequency up to 180 cycles per minute.

QUICK REFERENCE GUIDE

Product Number	Inlet Connection Size (in.)	Max Liquid Pressure	Min Air Cylinder Pressure	Max Flow	Max Temp (liquid)	Max Speed	Spray Tips
JUAUH	1/4 NPT or BSPT (air and liquid)	125 psi (8.6 bar)	30 psi (2.1 bar)	0.8 gpm (3 lpm)	160°F (71°C)	180 cpm	TPU (page D6)
1/8JUAUH	1/8 NPT or BSPT (air and liquid)	125 psi (8.6 bar)	30 psi (2.1 bar)	0.3 gpm (1.1 lpm)	160°F (71°C)	180 cpm	TPU (page D6)
D55500-JAUH0	1/8 NPT or BSPT (air and liquid)	43 psi (3 bar)	72 psi (5 bar)	0.42 gpm (1.6 lpm)	158°F (70°C)	600 cpm	TPU or PWMD (page D6 & D13)
D55500-JAUH1	1/8 NPT or BSPT (air and liquid)	145 psi (10 bar)	72 psi (5 bar)	1.5 gpm (5.5 lpm)	158°F (70°C)	300 cpm	TPU or PWMD (page D6 & D13)
AA22AUH	1/8 NPT or BSPT (air) 1/4 NPS or BSPP (liquid)	600 psi (40 bar)	45 psi (3.1 bar)	5 gpm (18.9 lpm)	160°F (71°C)	180 cpm	TPU (page D6)
AA22AUH-7676	1/8 NPT or BSPT (air) 1/4 NPS or BSPP (liquid)	250 psi (17 bar)	45 psi (3.1 bar)	2 gpm (7.6 lpm)	160°F (71°C)	180 cpm	TPU (page D6)
AA22AUH-SS-11024	1/8 NPT or BSPT (air) 1/4 NPS or BSPP (liquid)	600 psi (40 bar)	45 psi (3.1 bar)	5 gpm (18.9 lpm)	160°F (71°C)	180 cpm	TPU (page D6)
AA24AUA	1/8 NPT or BPST (air) 1/4 NPS or BSPP (liquid)	4000 psi (275 bar)	75 psi (5.2 bar)	0.6 gpm (2.3 lpm)	160°F (71°C)	180 cpm	TP-TC (page D14)
AA24AUA-20190	1/8 NPT or BPST (air) 1/4 NPS or BSPP (liquid)	3000 psi (206 bar)	42 psi (2.9 bar)	0.6 gpm (2.3 lpm)	160°F (71°C)	180 cpm	TP-TC (page D14)
AA24AUA-8395	1/8 NPT or BPST (air) 1/4 NPS or BSPP (liquid)	4000 psi (275 bar)	75 psi (5.2 bar)	0.6 gpm (2.3 lpm)	160°F (71°C)	180 cpm	TP-TC (page D14)
AA24AUA-8980	1/8 NPT or BPST (air) 1/4 NPS or BSPP (liquid)	4000 psi (275 bar)	75 psi (5.2 bar)	0.6 gpm (2.3 lpm)	160°F (71°C)	180 cpm	TP-TC (page D14)



AIR-ACTUATED HYDRAULIC NOZZLE OPTIONS

JAUAH

- Compact design – 4.5" (114 mm) total length, 1.25 lbs. (0.57 kg) weight (approx.)
- Flow rates up to 0.8 gpm (3.0 lpm)
- Stainless steel or nickel-plated brass construction



1/8JJAUH

- Extra compact design – 2.75" (70 mm) total length, 6.5 oz. (184 g) weight (approx.)
- Flow rates up to 0.3 gpm (1.1 lpm)
- Construction: Stainless steel or nickel-plated brass



D55500-JAUHO

- Block design 30% smaller than standard 1/4JAUH
- Flow rates up to 0.42 gpm (1.6 lpm)
- Stainless steel construction with Viton® or EPDM seals
- Available with automatic spray tip alignment (15° or 30° offset angle)
- Available with plate mount and wall mount options



D55500-JAUH1

- Block design 30% smaller than standard 1/4JAUH
- Flow rates up to 1.5 gpm (5.5 lpm)
- Stainless steel construction with Viton or EPDM seals
- Available with automatic spray tip alignment (15° or 30° offset angle)
- Available with plate mount and wall mount options



AA22AUH

- Flow rates up to 5 gpm (18.9 lpm)
- Nickel-plated brass or stainless steel construction with PTFE packing material
- Mounting hole with locking screw for easy rod mounting



MORE OPTIONS

AA22AUH-7676 – Same as AA22AUH with flow rates up to 2 gpm (7.6 lpm) and available with extensions up to 36" (914 mm)

PLACING YOUR ORDER

Call 1.800.95.SPRAY for application assistance or to place an order.

FOR DETAILED SPRAY TIP PERFORMANCE DATA
SEE SECTION D

AIR-ACTUATED HYDRAULIC NOZZLE OPTIONS

AA22AUH-SS-11024

- Flow rates up to 5 gpm (18.9 lpm)
- Nickel-plated brass or stainless steel construction with PTFE packing material
- Mounting hole with locking screw for easy rod mounting
- Dual liquid inlets allow continuous liquid recirculation

**AA22AUH-SS-14799**

- Flow rates up to 2 gpm (7.6 lpm)
- Nickel-plated brass or stainless steel construction with PTFE packing material
- Mounting hole with locking screw for easy rod mounting
- Adjusting screw limits stroke length of shut-off needle for greater control of response time
- Specially designed for glue and other viscous spray applications

**AA24AUA**

- Flow rates up to 0.6 gpm (2.3 lpm)
- Nickel-plated brass or stainless steel construction with PTFE packing material
- Mounting hole with locking screw for easy rod mounting
- Rear knob locks the shut-off needle in place to prevent accidental discharge while changing spray tips
- Liquid inlet available in the standard "down" position or one of seven other positions in 45° increments

**AA24AUA-20190**

- Flow rates up to 0.6 gpm (2.3 lpm)
- Nickel-plated brass or stainless steel construction with PTFE packing material
- Mounting hole with locking screw for easy rod mounting
- Rear knob locks the shut-off needle in place to prevent accidental discharge while changing spray tips
- Aluminum body reduces total weight to just 1.25 lbs. (0.57 kg)

**AA24AUA-8395**

- Flow rates up to 0.6 gpm (2.3 lpm)
- Nickel-plated brass or stainless steel construction with PTFE packing material
- Mounting hole with locking screw for easy rod mounting
- Rear knob locks the shut-off needle in place to prevent accidental discharge while changing spray tips
- Dual liquid inlets allow continuous liquid recirculation

**AA24AUA-8980**

- Flow rates up to 0.6 gpm (2.3 lpm)
- Nickel-plated brass or stainless steel construction with PTFE packing material
- Mounting hole with locking screw for easy rod mounting
- Rear knob locks the shut-off needle in place to prevent accidental discharge while changing spray tips
- Available with extensions up to 36" (914 mm) long

**PLACING YOUR ORDER**

Call 1.800.95.SPRAY for application assistance or to place an order.

FOR DETAILED SPRAY TIP PERFORMANCE DATA
SEE SECTION D