

Automated Lube System Helps Truck Manufacturer Improve Product Quality and Reduce Oil Consumption by 25%



Problem:

Freightliner Trucks, a leading North American manufacturer of heavy-duty trucks, needed to coat 24" (609 mm) wide sheets of feed stock with lubricant prior to a stamping operation. The previous lubrication system did not apply the oil on the metal sheet evenly and caused quality problems. The system also generated wasteful overspray and covered nearby equipment and floors with oil, creating a slippery, hazardous work environment.

Solution:

An AutoJet® Lube System from Spraying Systems Co. has eliminated Freightliner's oil application problems. The system features a 36" (914 mm) coil lubricator which uses six hydraulic UniJet® nozzles for uniform coverage of the sheet. Each nozzle is supplied individually by an L210 air-actuated piston pump. All of the nozzles are contained within the coil lubricator unit.

An oil mist extractor is used in the coil lubricator to prevent worker inhalation and safety problems. The system also recirculates the oil, minimizing lubricant use. Automatic solenoid valves ensure excess oil is returned from the coil lubricator back to the supply tank. The oil is filtered on the suction lines to ensure no contaminants enter the system.

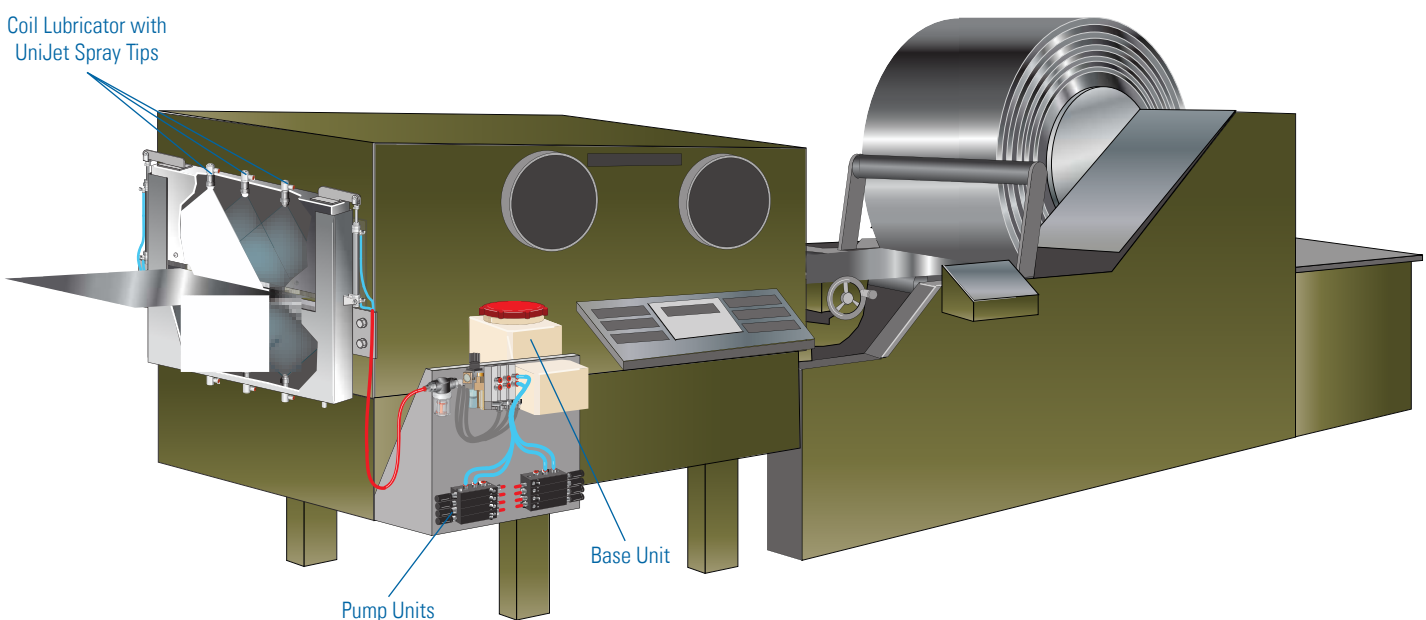



Automated Lube System Helps Truck Manufacturer Improve Product Quality and Reduce Oil Consumption by 25% – Continued

Results:

The AutoJet® Lube System has improved Freightliner's product quality. Scrap resulting from uneven lubrication has been reduced by 10%. Oil use has decreased by 25% – a significant reduction in operating costs. Another important benefit provided by the system is improved worker safety due to the elimination of overspray. Together, these factors save Freightliner an estimated US\$10,000 per year. The payback on the new lubrication system was about nine months.

A CLOSER LOOK AT THE SYSTEM

Coil lubricator contains six hydraulic UniJet spray tips which provide even coverage of lubricant across the width of the strip. The enclosed design of the coil lubricator and its connection to an oil mist extractor prevent misting and safety problems.



Base unit contains a 9.3 gallon (35 liter) supply tank for lubricating oil. An air-actuated membrane pump is included to accommodate the lubricating oils used. Air-actuated piston pumps in the mobile L210 base unit are used for the low viscosity lubricating emulsion.



UniJet® flat spray tips are available in a wide range of capacities.



Spraying Systems Co.®
Experts in Spray Technology

North Avenue and Schmale Road, P.O. Box 7900, Wheaton, IL 60187-7901 USA

Tel: 1.800.95.SPRAY Intl. Tel: 1.630.665.5000

Fax: 1.888.95.SPRAY Intl. Fax: 1.630.260.0842

www.spray.com



Case Study No. 173A Printed in the U.S.A. ©Spraying Systems Co. 2014