

OVERVIEW: AIR ATOMIZING SPRAY NOZZLE SET-UPS

- Each spray set-up – consisting of an air cap and a fluid cap – provides a specific spray pattern, flow rate and spray coverage
- Within each nozzle series, spray set-ups are interchangeable, for versatile performance
- Air and liquid can be externally or internally mixed to produce a completely atomized spray
- Drip Free™ spray set-ups are used for all nozzle assemblies containing shut-off or clean-out needles to ensure positive liquid shut-off

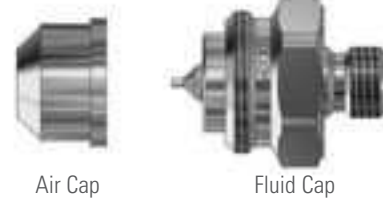

Air Cap

Fluid Cap

Spray Set-Ups

Each spray set-up consists of an air cap and a fluid cap.



Internal Mix Set-Ups

Liquid and air are mixed internally to produce an atomized spray. Liquid and gas streams are not independent – a change in air flow will affect the liquid flow.

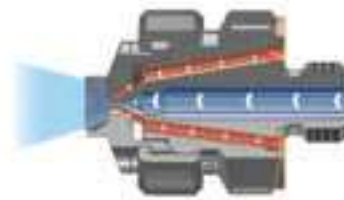

External Mix Set-Ups

Liquid and air streams are mixed outside of the nozzle. Air and liquid flow can be controlled independently. Effective for higher viscosity liquids and abrasive suspensions.

QUICK REFERENCE GUIDE

Spray Set-Up	Liquid Supply	Internal / External Mix	Spray Patterns	Max Flow	Page Number
1/8J and 1/4J Series	Pressure Feed Siphon/Gravity Feed	Both	<ul style="list-style-type: none"> • Flat Spray • Deflected Flat Spray • Round Spray • Wide Angle Round Spray • 360° Circular Spray 	72 gph (272.5 lph)	D22
1/8JJ Series	Pressure Feed Siphon/Gravity Feed	Both	<ul style="list-style-type: none"> • Flat Spray • Round Spray • Wide Angle Round Spray • 360° Circular Spray 	33.2 gph (126 lph)	D33
1/2J Series	Pressure Feed Siphon/Gravity Feed	Both	<ul style="list-style-type: none"> • Flat Spray • Round Spray • Wide Angle Round Spray 	306 gph (1158 lph)	D41
1J Series	Pressure Feed Siphon/Gravity Feed	Both	<ul style="list-style-type: none"> • Flat Spray • Round Spray • Wide Angle Round Spray 	29 gpm (110 lpm)	D45
QuickMist® Series	Pressure Feed Siphon/Gravity Feed	Internal Mix Only	<ul style="list-style-type: none"> • Flat Spray • Round Spray • Wide Angle Round Spray 	26 gpm (98 lpm)	D50
SUV and SUVM Series	Pressure Feed Only	External Mix Only	<ul style="list-style-type: none"> • Variable 	49.8 gph (188.5 lph)	D55



OVERVIEW: AIR ATOMIZING SPRAY FEED SET-UPS

- Liquid can be supplied to the nozzle under pressure or it can be supplied through a liquid siphon or gravity feed
- Filtration and pressure regulation are recommended on both the liquid and air line

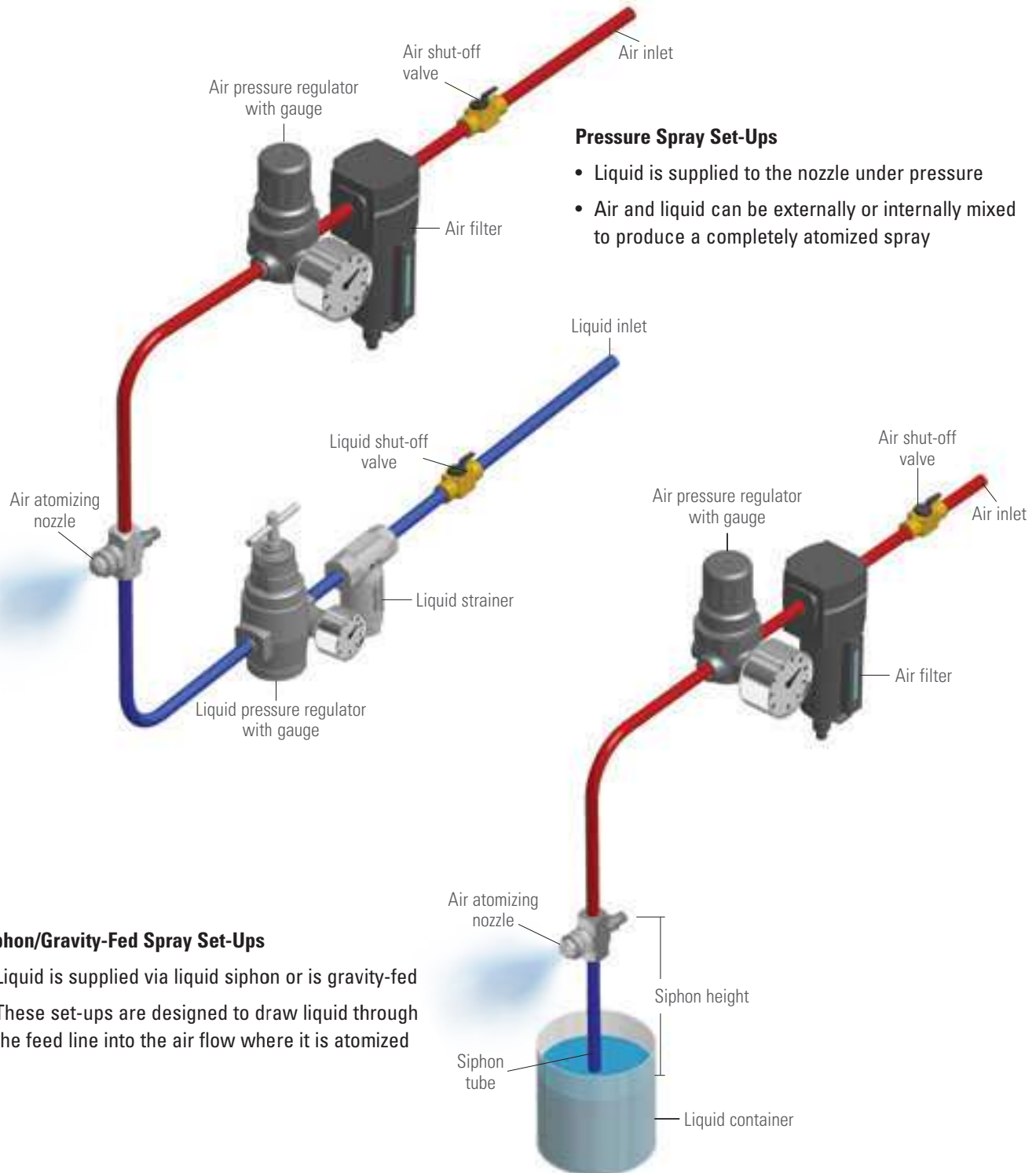

Pressure Spray Set-Ups

- Liquid is supplied to the nozzle under pressure
- Air and liquid can be externally or internally mixed to produce a completely atomized spray

Siphon/Gravity-Fed Spray Set-Ups

- Liquid is supplied via liquid siphon or is gravity-fed
- These set-ups are designed to draw liquid through the feed line into the air flow where it is atomized



PERFORMANCE DATA:
SIPHON/GRAVITY SPRAY SET-UPS | EXTERNAL MIX | ROUND SPRAY

For a round spray pattern, angle "A" is maintained throughout distance "B". Beyond "B", the spray becomes turbulent and projects out to distance "C".

Liquid is supplied to this spray set-up by either a liquid siphon or a gravity-feed.

Liquid is drawn through the feed line into the air flow where it is atomized.

When ordering only a spray set-up, 3199 retainer ring and 3612 gasket must be ordered separately. These components are included in a complete air atomizing nozzle assembly.

Please contact your sales engineer for more information.

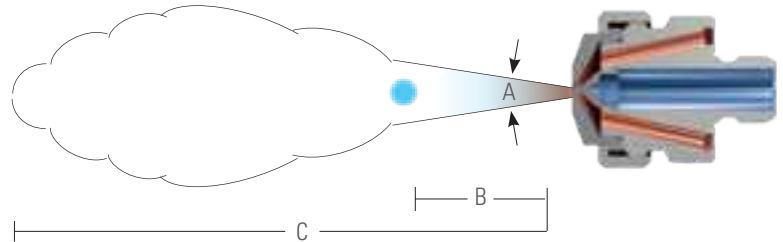

Spray Set-up No.	Spray Set-up Consists of Fluid and Air Cap Combination	Atomizing Air		Liquid Capacity (liters per hour)*								Spray Dimensions at 20 cm Siphon Height		
		Air Press.	Air Capacity l/min	Gravity Head (cm)			Siphon Height (cm)					Spray Angle A (°)	B (cm)	C (m)
				45	30	15	10	20	30	60	90			
SU1A	Fluid Cap 1650 + Air Cap 64	.70	11.3	1.5	1.3	1.1	.87	.68	.53	–	–	18	28 - 36	1.8 - 2.6
		1.5	17.0	1.8	1.7	1.5	1.3	1.2	1.1	.62	–			
		3.0	28	2.1	1.9	1.7	1.5	1.4	1.3	1.1	.76			
		4.0	36	2.2	2.0	1.8	1.6	1.5	1.4	1.2	.87			
SU1	Fluid Cap 2050 + Air Cap 64	.70	13.3	2.4	2.1	1.7	1.5	1.2	.79	–	–	18 - 19	30 - 43	2.1 - 3.0
		1.5	20	2.8	2.6	2.4	2.1	1.9	1.6	.91	–			
		3.0	32	3.4	3.1	2.9	2.8	2.6	2.4	1.7	1.1			
		4.0	41	3.7	3.4	3.3	3.1	2.9	2.7	2.1	1.5			
SU2A	Fluid Cap 2050 + Air Cap 70	.70	23	2.5	2.3	2.0	1.6	1.4	1.1	–	–	18 - 20	30 - 43	2.4 - 4.0
		1.5	36	2.9	2.8	2.5	2.2	2.0	1.7	.89	–			
		3.0	58	3.4	3.3	3.2	2.9	2.8	2.5	1.9	1.2			
		4.0	74	3.7	3.6	3.5	3.4	3.3	3.0	2.5	2.0			
SU2	Fluid Cap 2850 + Air Cap 70	.70	19.3	4.5	4.0	3.4	2.1	1.8	1.4	–	–	21 - 22	38 - 51	3.0 - 4.6
		1.5	31	5.3	4.9	4.4	3.5	2.9	2.7	1.8	–			
		3.0	50	6.0	5.6	5.0	4.4	4.0	3.4	2.4	1.2			
		4.0	65	5.7	5.4	5.0	4.2	3.9	3.5	2.8	1.9			
SU4	Fluid Cap 60100 + Air Cap 120	1.5	58	22	19.9	16.3	12.3	10.5	8.3	2.8	–	17 - 19	46 - 58	3.7 - 5.5
		3.0	88	25	23	19.5	16.7	14.2	11.5	6.4	2.8			
		4.0	111	26	24	21	18.4	15.7	12.9	7.9	4.5			
		5.6	147	26	24	22	19.7	17.0	14.6	9.8	6.1			
SU5	Fluid Cap 100150 + Air Cap 180	2.0	144	–	–	–	27	22	16.8	–	–	20 - 22	51 - 63	6.7 - 8.2
		3.0	190	–	–	–	30	26	21	–	–			
		4.0	240	–	43	40	31	28	23	11.0	–			
		5.6	315	44	42	39	31	28	24	16.7	8.3			

*At the stated pressure in bar.

Anti-bearding set-ups are available to reduce nozzle build-up and maintenance time for select external mix air atomizing nozzles. Drip Free™ spray set-ups ensure positive shut-off and are provided for air atomizing assemblies containing a shut-off needle. For more information, call 1.630.665.5000.



NUMBERING SYSTEM FOR AIR CAPS AND FLUID CAPS

The drawings below illustrate the measurements used in the Spray Performance Data charts.

**AIR CAPS
PRESSURE SET-UPS (INTERNAL MIX)**

Round Spray Pattern

Example: Air Cap No. PA67147



Wide Angle Round Spray Pattern

Example: Air Cap No. PA67-6-20-70

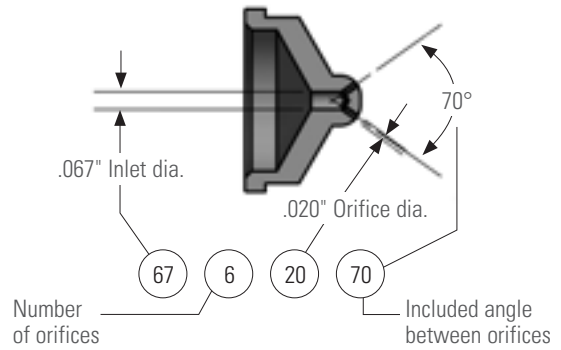

Flat Spray Pattern

Example: Air Cap No. PA73320

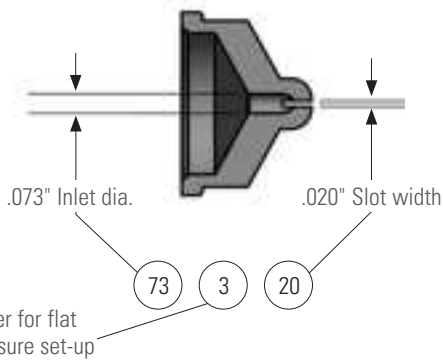

Dimensions shown are nominal and subject to manufacturing tolerances.

PLACING YOUR ORDER

**Call 1.630.665.5000 for application assistance
or to place an order.**

AIR CAPS

SIPHON/GRAVITY FEED SET-UPS (EXTERNAL MIX)

Round Spray Pattern

Example: Air Cap No. PA64

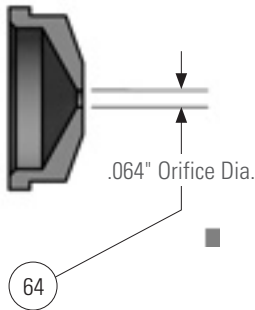

Flat Round Spray Pattern

Example: Air Cap No. PA73420

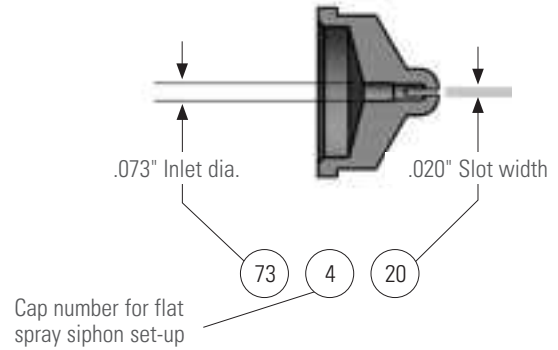

AIR CAPS

PRESSURE SET-UPS (EXTERNAL MIX)

Flat Spray Pattern

Example: Air Cap No. PA200278-45

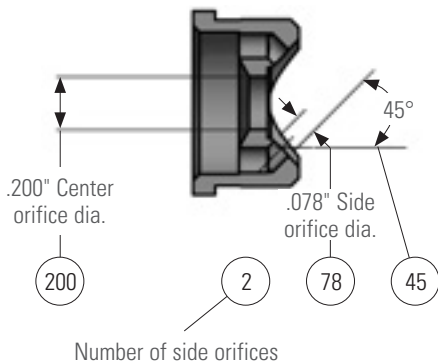

FLUID CAP

FOR USE WITH ALL SET-UPS

Fluid Cap

Example: Fluid Cap No. PF2850

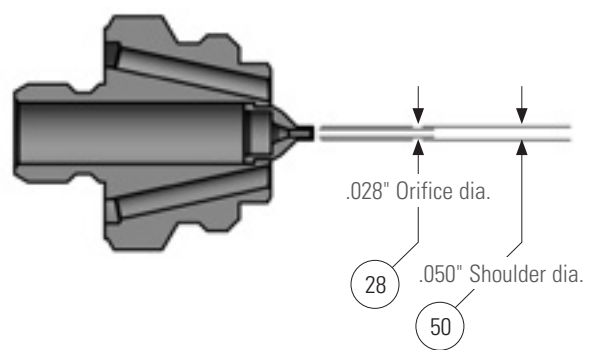

Dimensions shown are nominal and subject to manufacturing tolerances.

AIR ATOMIZING SET-UP COMPATIBILITY

Use the chart that follows to determine which spray set-ups can be used with our atomizing nozzles. The chart also includes the part number for the air cap and fluid cap that are required for each spray set-up.

Set-up No.	Spray Pattern	Use With	Fluid Cap No.	Air Cap No.
SU11	Round	1/8J,1/4J	PF2050	PA67147
SU12A	Round	1/8J,1/4J	PF2050	PA73160
SU12	Round	1/8J,1/4J	PF2850	PA73160
SU22B	Round	1/8J,1/4J	PF40100	PA1401110
SU22	Round	1/8J,1/4J	PF60100	PA1401110
SU42	Round	1/8J,1/4J	PF100150	PA1891125
SU16	Wide Angle Round	1/8J,1/4J	PF2050	PA67-6-20-70
SU26B	Wide Angle Round	1/8J,1/4J	PF40100	PA140-6-37-70
SU26	Wide Angle Round	1/8J,1/4J	PF60100	PA140-6-37-70
SU29	Wide Angle Round	1/8J,1/4J	PF60100	PA140-6-52-70
SU30	Wide Angle Round	1/8J,1/4J	PF40100	PA120-6-35-60
SU46	Wide Angle Round	1/8J,1/4J	PF100150	PA189-6-62-70
SU340C	360° Circular	1/8J,1/4J	PF60150	PA189-6-62-160HC
SU13A	Flat	1/8J,1/4J	PF2050	PA73328
SU13	Flat	1/8J,1/4J	PF2850	PA73328
SUN13	Flat	1/8J,1/4J	PF2850	PA73335
SU14	Flat	1/8J,1/4J	PF2850	PA73320
SUN23	Flat	1/8J,1/4J	PF60100	PA125340
SU23B	Flat	1/8J,1/4J	PF40100	PA125328
SU23	Flat	1/8J,1/4J	PF60100	PA125328
SU43	Flat	1/8J,1/4J	PF100150	PA189351
SU240E	Deflected Flat	1/8J,1/4J	PF28150	PA189110-75

Set-up No.	Spray Pattern	Use With	Fluid Cap No.	Air Cap No.
SUE15B	Flat	1/8J,1/4J	PF1650	PA67228-45
SUE18B	Flat	1/8J,1/4J	PF1650	PA62240-60
SUE15A	Flat	1/8J,1/4J	PF2050	PA67228-45
SUE18A	Flat	1/8J,1/4J	PF2050	PA62240-60
SUE15	Flat	1/8J,1/4J	PF2850	PA67228-45
SUE18	Flat	1/8J,1/4J	PF2850	PA62240-60
SUE25B	Flat	1/8J,1/4J	PF35100	PA134255-45
SUE28B	Flat	1/8J,1/4J	PF35100	PA122281-60
SUE25A	Flat	1/8J,1/4J	PF40100	PA134255-45
SUE28A	Flat	1/8J,1/4J	PF40100	PA122281-60
SUE28	Flat	1/8J,1/4J	PF60100	PA122281-60
SUE25	Flat	1/8J,1/4J	PF60100	PA134255-45
SUE45B	Flat	1/8J,1/4J	PF60150	PA200278-45
SUE45A	Flat	1/8J,1/4J	PF80150	PA200278-45
SUE45	Flat	1/8J,1/4J	PF100150	PA200278-45
SUF1	Flat	1/8J,1/4J	PF2850	PA73420
SUF2C	Flat	1/8J,1/4J	PF35100	PA120432
SUF3B	Flat	1/8J,1/4J	PF40100	PA122435
SUF4B	Flat	1/8J,1/4J	PF40100	PA122440
SU1A	Round	1/8J,1/4J	PF1650	PA64
SU1	Round	1/8J,1/4J	PF2050	PA64
SU2A	Round	1/8J,1/4J	PF2050	PA70



Set-up No.	Spray Pattern	Use With	Fluid Cap No.	Air Cap No.
SU2	Round	1/8J,1/4J	PF2850	PA70
SU4	Round	1/8J,1/4J	PF60100	PA120
SU5	Round	1/8J,1/4J	PF100150	PA180
D-SU1A-W D-SU1A-W-CO	Wide Angle Round	1/8J,1/4J	Fluid caps and air caps not sold separately.	
D-SU1-W D-SU1-W-CO	Wide Angle Round	1/8J,1/4J		
D-SU2A-W D-SU2A-W-CO	Wide Angle Round	1/8J,1/4J		
D-SU2-W D-SU2-W-CO	Wide Angle Round	1/8J,1/4J		
D-SU4-W D-SU4-W-CO	Wide Angle Round	1/8J,1/4J		
D-SU5-W D-SU5-W-CO	Wide Angle Round	1/8J,1/4J		
SUJ11	Round	1/8JJ	PFJ2050	PAJ67147
SUJ12A	Round	1/8JJ	PFJ2050	PAJ73160
SUJ12	Round	1/8JJ	PFJ2850	PAJ73160
SUJ22B	Round	1/8JJ	PFJ40100	PAJ1401110
SUJ22	Round	1/8JJ	PFJ60100	PAJ1401110
SUJ340C	360° Circular	1/8JJ	PFJ60100	PAJ150-6-62-160HC
SUJ16	Wide Angle Round	1/8JJ	PFJ2050	PAJ67-6-20-70
SUJ26B	Wide Angle Round	1/8JJ	PFJ40100	PAJ140-6-37-70
SUJ26	Wide Angle Round	1/8JJ	PFJ60100	PAJ140-6-37-70
SUJ29	Wide Angle Round	1/8JJ	PFJ60100	PAJ140-6-52-70
SUJ30	Wide Angle Round	1/8JJ	PFJ40100	PAJ120-6-35-60
SUJ13A	Flat	1/8JJ	PFJ2050	PAJ73328
SUJ13	Flat	1/8JJ	PFJ2850	PAJ73328
SUJ14	Flat	1/8JJ	PFJ2850	PAJ73320
SUJ23B	Flat	1/8JJ	PFJ40100	PAJ125328

Set-up No.	Spray Pattern	Use With	Fluid Cap No.	Air Cap No.
SUJ23	Flat	1/8JJ	PFJ60100	PAJ125328
SUJE416-50	Flat	1/8JJ	PFJ1650	PAJ105-50
SUJE417-50	Flat	1/8JJ	PFJ2050	PAJ105-50
SUJE418-50	Flat	1/8JJ	PFJ2850	PAJ105-50
SUJE420-50	Flat	1/8JJ	PFJ40100	PAJ135-50
SUJE416-65	Flat	1/8JJ	PFJ1650	PAJ080-65
SUJE417-65	Flat	1/8JJ	PFJ2050	PAJ080-65
SUJE418-65	Flat	1/8JJ	PFJ2850	PAJ080-65
SUJE420-65	Flat	1/8JJ	PFJ40100	PAJ125-65
SUJE421-65	Flat	1/8JJ	PFJ60100	PAJ-125-65
SUJE416-90	Flat	1/8JJ	PFJ1650	PAJ075-90
SUJE417-90	Flat	1/8JJ	PFJ2050	PAJ075-90
SUJE418-90	Flat	1/8JJ	PFJ2850	PAJ075-90
SUJE420-90	Flat	1/8JJ	PFJ40100	PAJ115-90
SUJE421-90	Flat	1/8JJ	PFJ60100	PAJ115-90
SUJ1A	Round	1/8JJ	PFJ1650	PAJ64
SUJ1	Round	1/8JJ	PFJ2050	PAJ64
SUJ2A	Round	1/8JJ	PFJ2050	PAJ70
SUJ2	Round	1/8JJ	PFJ2850	PAJ70
SUJ3	Round	1/8JJ	PFJ2850	PAJ64-5
SUJ4B	Round	1/8JJ	PFJ40100	PAJ120
SUJ4	Round	1/8JJ	PFJ60100	PAJ120
SUJF1	Flat	1/8JJ	PFJ2850	PAJ73420
SUJF2C	Flat	1/8JJ	PFJ35100	PAJ120432



Set-up No.	Spray Pattern	Use With	Fluid Cap No.	Air Cap No.
SUJF3B	Flat	1/8JJ	PFJ40100	PAJ122435
SUJF4B	Flat	1/8JJ	PFJ40100	PAJ122440
SU75	Flat	1/2J	PF250375	PA4533102
SU85	Flat	1/2J	PF251376	PA4693102
SU77	Wide Angle Round	1/2J	PF250375	PA422-6-73-70
SU78	Wide Angle Round	1/2J	PF250375	PA422-6-94-70
SU79	Wide Angle Round	1/2J	PF250375	PA469-6-125-70
SU89	Wide Angle Round	1/2J	PF251376	PA469-6-130-70
SU72	Round	1/2J	PF250375	PA4221250
SU82	Round	1/2J	PF251376	PA4691312
SUE75	Flat	1/2J	PF250375	PA14356
SU159	Wide Angle Round	1J	PF4371000	PA1109-6-224-70
SU152	Round	1J	PF4371000	PA11091547
SU172	Round	1J	PF6251000	PA11251625
SU155	Flat	1J	PF4371000	PA11093187
SUE175B	Flat	1J	PF625780	PA12116
SU170	Round	1J	PF6251000	PA1125
SUQR-220B	Round	QMJ	PFQ40	PAQR95
SUQW-260B	Wide Angle Round	QMJ	PFQ30	PAQW37-60
SUQW-260	Wide Angle Round	QMJ	PFQ60	PAQW37-60
SUQW-290	Wide Angle Round	QMJ	PFQ60	PAQW52-60
SUQF-130	Flat	QMJ	PFQ20	PAQF28
SUQF-N130	Flat	QMJ	PFQ30	PAQF28
SUQF-230B	Flat	QMJ	PFQ30	PAQF35
SUQF-230	Flat	QMJ	PFQ40	PAQF40
SUQR-200	Round	QMJ	PFQ5028	PAQR070
SUQR-300	Round	QMJ	PFQ10060	PAQR120
SUQF-200C	Flat	QMJ	PFQ10035	PAQF450121

Set-up No.	Spray Pattern	Use With	Fluid Cap No.	Air Cap No.
SUQR-300B	Flat	QMJ	PFQ10040	PAQF450121
SUQF-300	Flat	QMJ	PFQ10060	PAQF450121
SUVM67B	Variable	VMAU	VMF1650	VMA67255-60
SUVM67A	Variable	VMAU	VMF2050	VMA67255-60
SUVM67	Variable	VMAU	VMF2850	VMA67255-60
SUVM113A	Variable	VMAU	VMF3578	VMA113289-60
SUVM113	Variable	VMAU	VMF4078	VMA113289-60
SUVM128	Variable	VMAU	VMF60100	VMA1282100-60
SUVM152	Variable	VMAU	VMF80125	VMA1522110-60
SUV67B	Variable	VAU	VF1650	VA67255-60
SUV67A	Variable	VAU	VF2050	VA67255-60
SUV67	Variable	VAU	VF2850	VA67255-60
SUV113A	Variable	VAU	VF3578	VA113293-60
SUV113	Variable	VAU	VF4078	VA113293-60
SUV128	Variable	VAU	VF60100	VA1282125-60
SUV152	Variable	VAU	VF80125	VA1522125-60
SUVXE1A	Flat	VX	PFX16	PAVX140A
SUVXE2C	Flat	VX	PFX16	PAVX156A
SUVXE1	Flat	VX	PFX20	PAVX140A
SUVXE2B	Flat	VX	PFX20	PAVX156A
SUVXE2A	Flat	VX	PFX28	PAVX156A
SUVXE3B	Flat	VX	PFX28	PAVX180A
SUVXE2	Flat	VX	PFX40	PAVX156A
SUVXE3A	Flat	VX	PFX40	PAVX180A
SUVXE3	Flat	VX	PFX60	PAVX180A
SUVXE4B	Flat	VX	PFX60	PAVX200A
SUVXE4A	Flat	VX	PFX80	PAVX200A
SUVXE4	Flat	VX	PFX100	PAVX200A

