



PHARMACEUTICAL & BIOPHARMACEUTICAL PROCESSING

TABLET COATING, HIGH-SHEAR GRANULATION,
FLUID BED PROCESSING, VESSEL/EQUIPMENT
CLEANING, SPRAY DRYING



Spraying Systems Co.[®]

Experts in Spray Technology

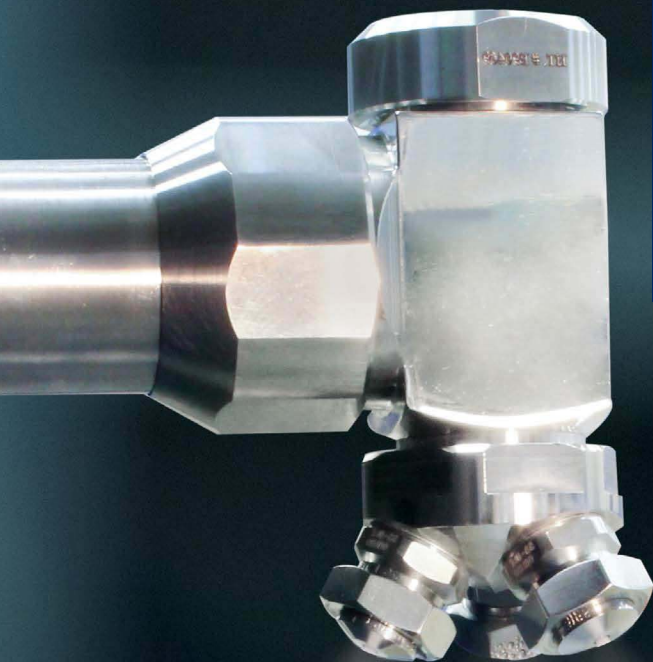



COMPLETE SPRAY SOLUTIONS FOR PHARMACEUTICAL PROCESSING

DEDICATED TO MEETING YOUR cGMP REQUIREMENTS

As the world's expert in spray technology, Spraying Systems Co. has partnered with leading pharmaceutical manufacturers and researchers to develop new spray products that improve product quality and process efficiency. With these new technologies in hand, we are able to provide:

- Solutions that meet your cGMP requirements
- Products designed in compliance with ASME BPE standards
- Extensive turnover packages detailing every aspect of our fabrication process
- Testing services available to optimize any spray application
- Assist in defining SOP
- Customized products and set-ups that meet your complex needs
- Outstanding service and support through our global network of sales offices

APPLICATIONS

SOLID DOSAGE

- Tablet coating
- High-shear granulation
- Fluid bed coating (Wurster process) and granulation
- Cleaning
- Spray Drying

BIOPHARMACEUTICAL

- Clean in Place
- Foam Control
- Corrosive

TABLET COATING

REDUCED PROCESS RISK AND IMPROVED COMPLIANCE WITH YOUR QUALITY STANDARDS

- Superior surface finish of 20µin Ra reduces contamination risk
- Manufactured to cGMP guidelines
- Patented design meets ASME BPE specifications
- Anti-bearding spray set-ups significantly reduce clogging and improves coating

EASIER TO OPERATE AND MAINTAIN

54000 Manifold

- Half the weight of other manufacturer's designs
- Disassembles in seconds, saving time and money
- Polished 316/316L stainless steel

Tabcoater Manifold

- Patent pending modular guns with recirculation feature - built-in shut-off valves keep liquid moving, eliminating clogging
- Individually fed spray guns provide more precise and error-free operation
- Designed to prevent tablet entrapment

FOR FURTHER INFORMATION: spray.com/pharmacatalog

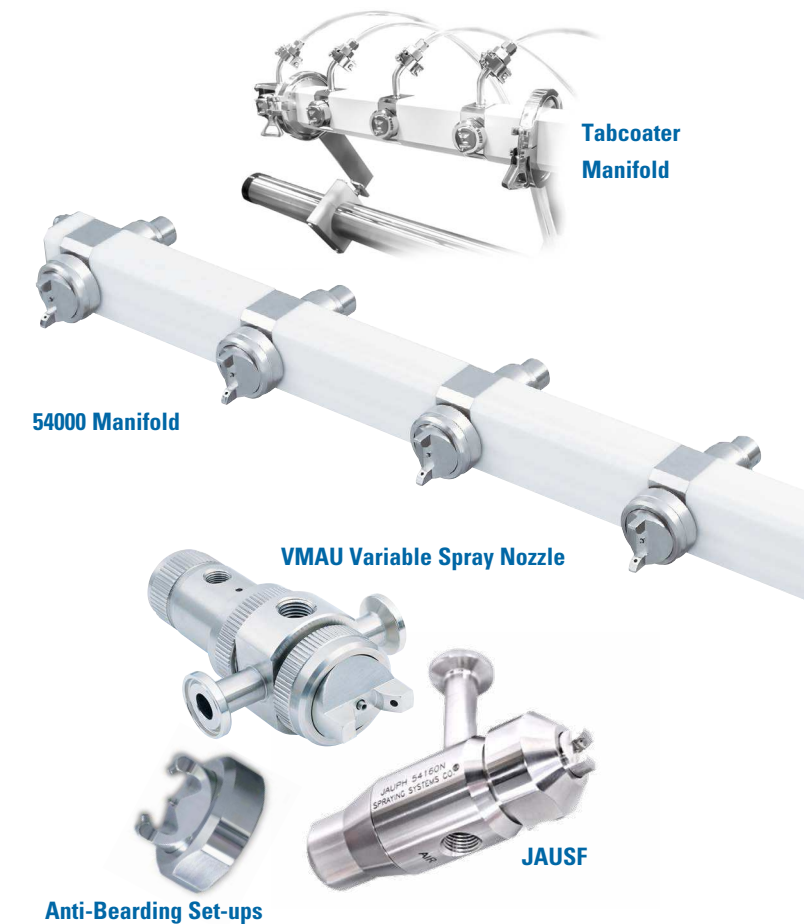

FLUID BED AND GRANULATION

FLUID BED NOZZLES - IMPROVE GRANULATION AND COATING

- Fully customizable fluid bed nozzles
- Designed to simplify your scale-up, reduce maintenance, and improve batch quality
- Now available from R&D sizes through full production scale

FULLY CUSTOMIZED LANCES FOR YOUR HIGH-SHEAR GRANULATION APPLICATION

- Completely customizable, designed to fit your mixer's exact specifications
- Threadless, sanitary design – all components are welded in place
- Materials of construction: 316L stainless steel

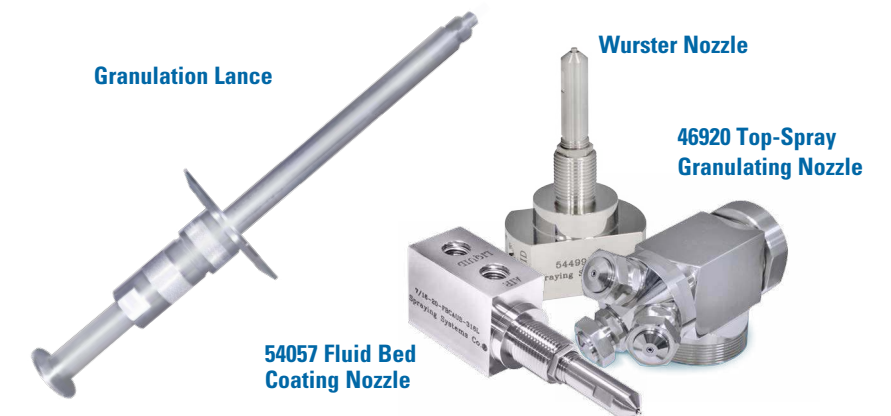

SPRAY RESEARCH & PERFORMANCE TESTING

Optimizing your spray system not only ensures product quality, but can save you significant costs. We have the ability to extensively test and research products with our state-of-the-art laboratory equipment.

We continue to lead the spray industry in testing and research capabilities to provide the most effective solutions for the pharmaceutical industry.

For more information about our testing capabilities, visit sprayconsultants.com.

VESSEL/EQUIPMENT CLEANING

CLEANING SOLUTIONS FOR END USER AND ORIGINAL EQUIPMENT MANUFACTURERS

Static Nozzles & Wands

- Standard and custom spray balls
- Exotic alloys and non-metallics
- Unique integration of nozzles and wand designs

Rotary Nozzles

- Regulated and non-regulated, liquid-driven
- Liquid hydraulic bearings are self-flushing & draining
- Metallic and non-metallic materials

HYGIENIC MANUFACTURING

- Manufactured to cGMP standards
- Engineering group with extensive knowledge of ASME BPE design standards
- Data requirement options: passivation, electropolish, surface finish, flow, and welder certificates. Material Test Reports (MTRs) and NDE.
- Welders are BPVC Sect. IX compliant



SPRAY DRYING

SPRAYDRY® NOZZLES FOR COMPLETE PARTICLE SIZE CONTROL

- Clog resistant
- Easy to maintain



FOR MORE SPRAYDRY® INFORMATION REFER TO: **Bulletin 695**

Cover photo courtesy of Thomas Engineering Inc.

Hastelloy® is a registered trademark of Haynes International, Inc.

ASME is a registered trademark of American Society of Mechanical Engineers (ASME, ASME International)



Spraying Systems Co.®
Experts in Spray Technology

North Avenue and Schmale Road, P.O. Box 7900, Wheaton, IL 60187-7901 USA

Tel: 1.800.95.SPRAY Intl. Tel: 1.630.665.5000

Fax: 1.888.95.SPRAY Intl. Fax: 1.630.260.0842

www.spray.com www.spray.com/pharmacatalog



Bulletin No. 599C

Printed in the U.S.A. ©Spraying Systems Co. 2014