

HERCULES DRAWN STEEL SAVES US\$50,000 IN OIL COSTS WITH AUTOJET® PRECISION SPRAY SYSTEM



PROBLEM:

Hercules Drawn Steel used an air atomizing nozzle to apply a rust inhibitor to finished steel bars. The oil was being over-applied to ensure full coverage. In addition to being wasteful, the nozzle was creating worker safety and maintenance issues. Excess oil dripped onto the floor creating slip hazards and misting compromised air quality. Removing the oil from the floors and surrounding equipment was time consuming and costly. Hercules turned to Spraying Systems Co. for help.

SOLUTION:

Oil is now applied to the finished steel bars with an AutoJet Precision Lubrication system. The system consists of four PulsaJet® electrically-actuated hydraulic spray nozzles and an AutoJet spray control panel. The bars are coated uniformly with the proper volume of oil, even when operating conditions such as line speed changes. In addition, the nozzles are triggered to spray only when the bars are properly positioned in the spray station further reducing oil waste.

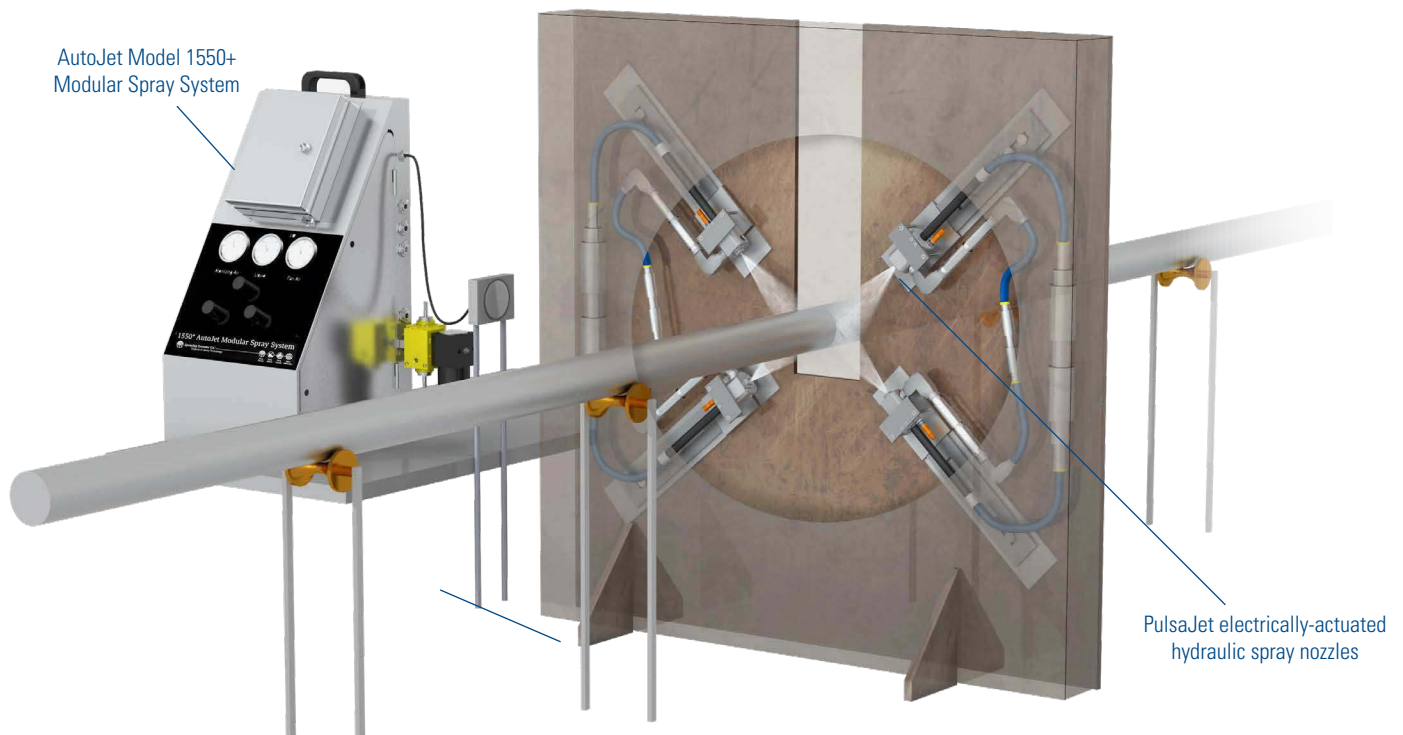

HERCULES DRAWN STEEL SAVES US\$50,000 IN OIL COSTS WITH AUTOJET® PRECISION SPRAY SYSTEM

– Continued

RESULTS:

Applying the proper volume of oil on the steel bars without waste, has enabled Hercules to reduce oil use by 25 gallons (95 liters) per day and save more than US\$50,000 annually. Hercules has also experienced additional savings by eliminating the compressed air previously required for the air atomizing nozzle and by

the maintenance time required to clean up excess oil. More importantly, worker safety has been improved. Hercules recouped the cost of the AutoJet Precision Lubrication system in less than three months.

A CLOSER LOOK AT THE SYSTEM



Pulsajet® electrically-actuated hydraulic spray nozzles provide high transfer efficiency to minimize waste and messy overspray. Pulsajet nozzles can be used with a variety of spray tips to ensure the performance matches the application requirements.

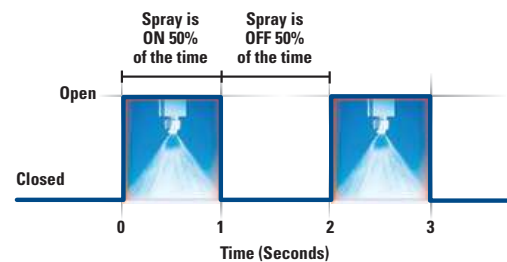

AutoJet Precision Lubrication provides automated spray control of nozzles to ensure precise, accurate placement of the oil on steel bars with minimal waste.



Precision Spray Control (PSC) involves turning nozzles on and off very quickly to control flow rate. This cycling is so fast that the flow often appears to be constant. With traditional nozzles, flow rate adjustments require a change in liquid pressure, which also changes the nozzle's spray angle, coverage and drop size. With PSC, pressure remains constant enabling flow rate changes without changes in spray performance. PSC requires the use of electrically-actuated spray nozzles and an AutoJet spray controller.

For more information about Precision Spray Control, visit spray.com/psc



Spraying Systems Co.®

Experts in Spray Technology

North Avenue and Schmale Road, P.O. Box 7900, Wheaton, IL 60187-7901 USA

Tel: 1.800.95.SPRAY

Intl. Tel: 1.630.665.5000

Fax: 1.888.95.SPRAY

Intl. Fax: 1.630.260.0842

www.spray.com



Case Study No. 260 ©Spraying Systems Co. 2018