

OVERVIEW: AIR ATOMIZING SPRAY NOZZLE SET-UPS

- Each spray set-up – consisting of an air cap and a fluid cap – provides a specific spray pattern, flow rate and spray coverage
- Within each nozzle series, spray set-ups are interchangeable, for versatile performance
- Air and liquid can be externally or internally mixed to produce a completely atomized spray
- Drip Free™ spray set-ups are used for all nozzle assemblies containing shut-off or clean-out needles to ensure positive liquid shut-off

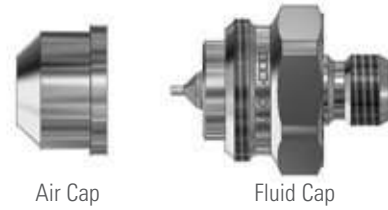

Spray Set-Ups

Each spray set-up consists of an air cap and a fluid cap.

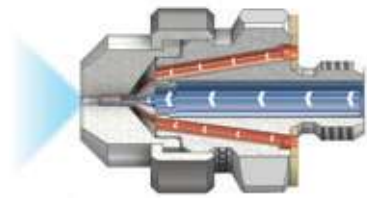

Internal Mix Set-Ups

Liquid and air are mixed internally to produce an atomized spray. Liquid and gas streams are not independent – a change in air flow will affect the liquid flow.

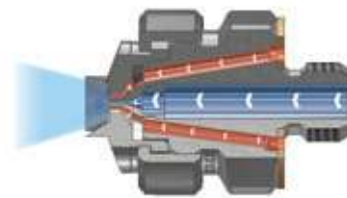

External Mix Set-Ups

Liquid and air streams are mixed outside of the nozzle. Air and liquid flow can be controlled independently. Effective for higher viscosity liquids and abrasive suspensions.

QUICK REFERENCE GUIDE

Spray Set-Up	Liquid Supply	Internal / External Mix	Spray Patterns	Max Flow	Page Number
1/4J Series	Pressure Feed Siphon/Gravity Feed	Both	<ul style="list-style-type: none"> • Flat Spray • Deflected Flat Spray • Round Spray • Wide Angle Round Spray • 360° Circular Spray 	72 gph (272.5 lph)	D24
1/8JJ Series	Pressure Feed Siphon/Gravity Feed	Both	<ul style="list-style-type: none"> • Flat Spray • Round Spray • Wide Angle Round Spray • 360° Circular Spray 	33.2 gph (126 lph)	D35
1/2J Series	Pressure Feed Siphon/Gravity Feed	Both	<ul style="list-style-type: none"> • Flat Spray • Round Spray • Wide Angle Round Spray 	306 gph (1158 lph)	D43
1J Series	Pressure Feed Siphon/Gravity Feed	Both	<ul style="list-style-type: none"> • Flat Spray • Round Spray • Wide Angle Round Spray 	29 gpm (110 lpm)	D49
QuickMist® Series	Pressure Feed Siphon/Gravity Feed	Internal Mix Only	<ul style="list-style-type: none"> • Flat Spray • Round Spray • Wide Angle Round Spray 	26 gpm (98 lpm)	D54
SUV and SUVM Series	Pressure Feed Only	External Mix Only	<ul style="list-style-type: none"> • Variable 	49.8 gph (188.5 lph)	D59 & D62



OVERVIEW: AIR ATOMIZING SPRAY FEED SET-UPS

- Liquid can be supplied to the nozzle under pressure or it can be supplied through a liquid siphon or gravity feed
- Filtration and pressure regulation are recommended on both the liquid and air line

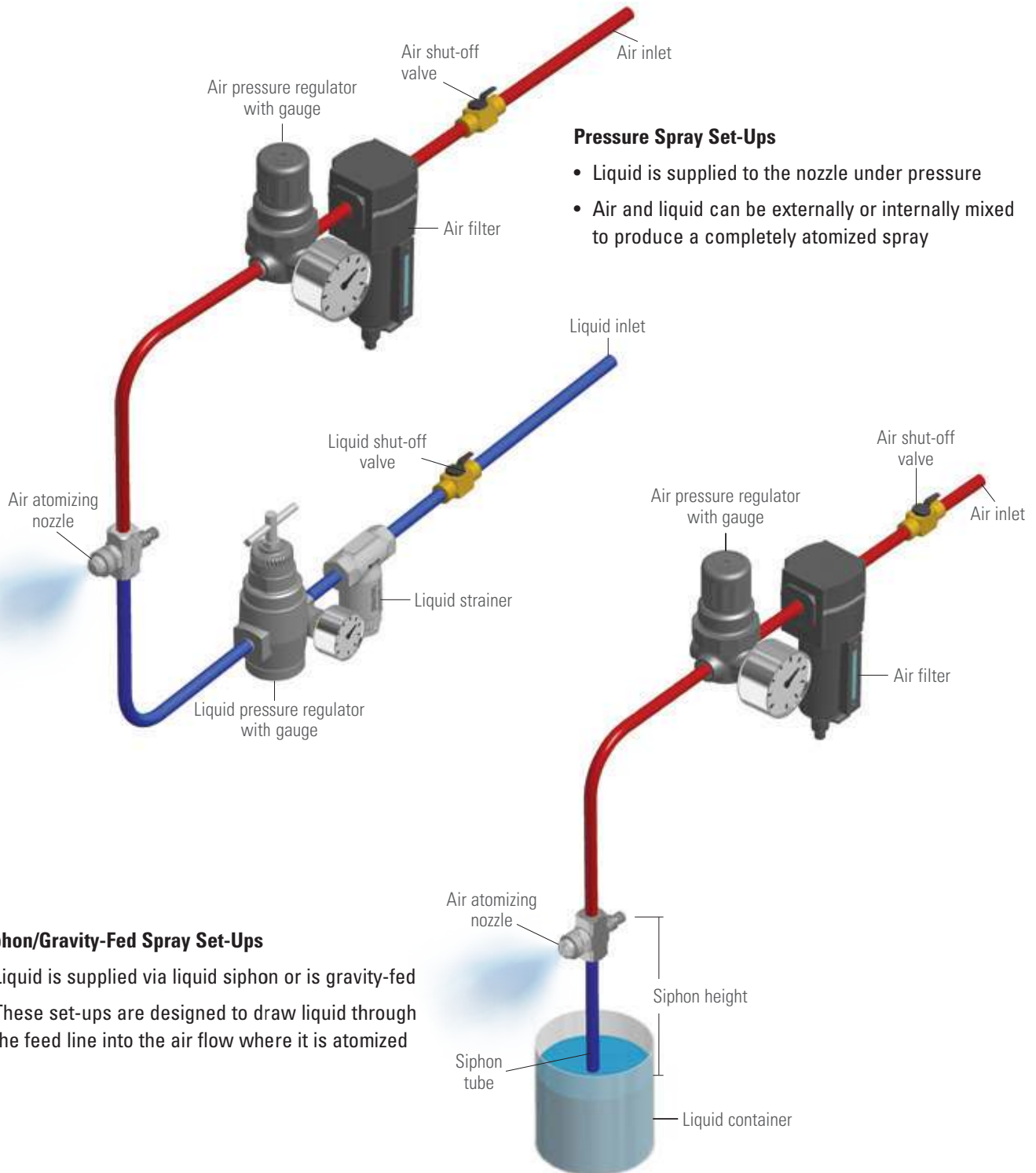

Pressure Spray Set-Ups

- Liquid is supplied to the nozzle under pressure
- Air and liquid can be externally or internally mixed to produce a completely atomized spray

Siphon/Gravity-Fed Spray Set-Ups

- Liquid is supplied via liquid siphon or is gravity-fed
- These set-ups are designed to draw liquid through the feed line into the air flow where it is atomized



**PERFORMANCE DATA:
PRESSURE SPRAY SET-UPS | EXTERNAL MIX | VARIABLE SPRAY**

SUVM spray set-ups provide uniform spray distribution even when spraying viscous liquids.

Liquid is supplied to this spray set-up under pressure.

The liquid and compressed air or gas are mixed externally to produce a completely atomized spray.

For external mix spray set-ups, atomization can be controlled by varying the air pressure without changing liquid flow rate.

Independent control of fan air provides the ability to adjust the spray pattern without changing liquid flow rate.

Spray coverage dimensions are provided in the table below at various distances from the nozzle.

Please contact your sales engineer for more information.

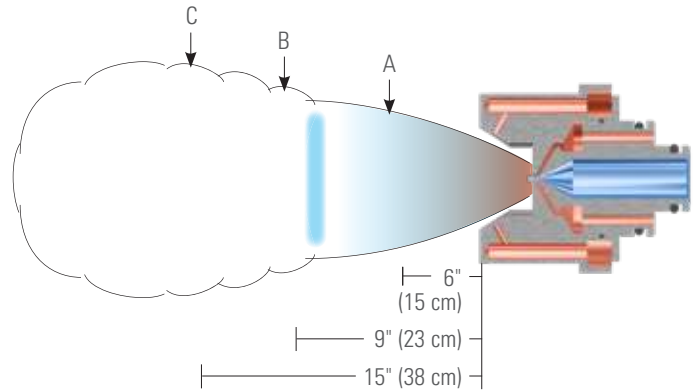

Spray Set-up No.	Spray Set-up Consists of Fluid and Air Cap Combination	Air Capacity*			Liquid Capacity*		Spray Coverage (in.) at Indicated Distance from Nozzle Fan Air Pressure																						
		Press.	Capacity		Press.	Cap. gph	Atom. Air Press.	Water Press.	0			5			10			20			30			40					
			Atomizing Air scfm	Fan Air scfm					A	B	C	A	B	C	A	B	C	A	B	C	A	B	C						
SUVM67B	Fluid Cap VMF1650 + Air Cap VMA67255-60	10.0	.58	2.0	1.0	.44	10.0	3.0	2.0	3.0	4.0	5.0	6.0	7.0	7.0	9.0	10.0	7.0	9.0	11.0	3.5	4.0	6.0	-	-	-			
									10.0	2.5	3.5	4.5	6.0	8.0	7.0	7.0	9.0	11.0	8.0	10.0	12.0	3.5	4.0	5.5	-	-	-		
									20	-	-	-	6.0	9.0	8.0	8.0	12.0	13.0	10.0	12.0	14.0	3.5	5.5	7.0	-	-	-		
		20	.84	3.1	3.0	.74	20	3.0	2.0	3.0	4.5	4.0	5.0	6.0	6.0	7.0	8.0	7.0	9.0	10.0	8.0	10.0	12.0	4.5	5.0	6.0	7.0	8.0	10.0
								10.0	2.0	3.0	4.0	5.0	7.0	7.0	7.0	9.0	10.0	8.0	10.0	12.0	4.5	5.0	6.0	7.0	8.0	10.0			
								20	2.0	3.0	4.0	6.0	7.0	8.0	8.0	10.0	12.0	9.0	12.0	14.0	6.0	7.5	9.0	7.0	8.0	10.0			
		30	1.1	3.9	5.0	1.0	30	3.0	2.0	3.0	4.5	3.0	4.0	5.0	5.0	6.0	7.0	6.0	8.0	10.0	5.5	6.0	7.0	7.0	9.0	11.0			
								10.0	2.0	3.0	4.5	4.0	4.5	6.0	6.0	7.5	10.0	7.0	9.0	11.0	5.5	6.5	8.0	7.0	9.0	12.0			
								20	2.0	3.0	4.0	4.5	6.0	7.0	7.0	9.0	12.0	8.0	10.0	12.0	6.0	7.0	9.0	8.0	9.0	11.0			
		40	1.8	6.6	10.0	1.4	40	3.0	2.5	3.5	6.0	3.5	4.5	5.0	5.0	6.0	8.0	6.0	8.0	10.0	5.0	6.5	8.0	7.0	9.0	11.0			
								10.0	2.0	3.0	5.0	4.0	5.0	5.0	5.0	7.0	9.0	7.0	9.0	11.0	6.0	7.5	9.0	7.0	9.0	11.0			
								20	2.0	3.0	4.5	4.0	5.5	6.0	6.0	8.0	10.0	8.0	9.0	11.0	6.0	7.5	10.0	8.0	10.0	12.0			
		60	2.0	7.5	15.0	1.7	60	3.0	2.5	3.5	6.0	3.0	4.5	4.0	4.0	5.0	6.0	5.0	7.0	9.0	5.0	6.5	10.0	7.0	9.0	11.0			
								10.0	2.5	3.0	5.0	3.5	4.0	4.5	4.5	5.0	7.0	7.0	9.0	11.0	6.0	7.5	11.0	8.0	10.0	12.0			
								20	2.0	3.0	4.5	3.5	5.0	5.0	5.0	7.0	9.0	7.0	9.0	11.0	6.0	7.5	11.5	8.0	10.0	12.0			

*At the stated pressure in psi.

Anti-bearding set-ups are available to reduce nozzle build-up and maintenance time for select external mix air atomizing nozzles. For more information, call 1.800.95.SPRAY.



**PERFORMANCE DATA:
PRESSURE SPRAY SET-UPS | EXTERNAL MIX | VARIABLE SPRAY**

Spray Set-up No.	Spray Set-up Consists of Fluid and Air Cap Combination	Air Capacity*			Liquid Capacity*		Spray Coverage (in.) at Indicated Distance from Nozzle Fan Air Pressure																				
		Press.	Capacity		Press.	Cap. gph	Atom. Air Press.	Water Press.	0			5			10			20			30			40			
			Atomizing Air scfm	Fan Air scfm					A	B	C	A	B	C	A	B	C	A	B	C	A	B	C	A	B	C	
SUV67A	Fluid Cap VMF2050 + Air Cap VMA67255-60	10.0	.58	2.0	1.0	.65	10.0	3.0	2.0	3.0	4.0	5.0	6.0	8.0	7.0	9.0	10.0	7.0	9.0	11.0	3.5	4.0	4.5	-	-	-	
			.73	2.6		10.0		2.5	3.5	4.5	6.0	8.0	9.5	7.0	9.0	11.0	8.0	10.0	12.0	4.5	5.0	6.0	-	-	-		
			.84	3.1		20		-	-	-	6.0	9.0	11.0	8.0	12.0	13.0	10.0	12.0	14.0	7.0	8.5	9.5	-	-	-		
		20	1.1	3.0	3.0	1.1	20	3.0	2.0	3.0	4.5	4.0	5.0	6.0	6.0	7.0	8.0	7.0	9.0	11.0	5.0	7.0	8.5	7.0	8.0	10.0	
			.84	3.1		10.0		2.0	3.0	4.0	5.0	7.0	9.0	7.0	9.0	10.0	8.0	10.0	12.0	6.0	7.0	8.0	7.0	8.0	10.0		
			1.1	3.9		20		2.0	3.0	4.0	6.0	7.0	9.0	8.0	10.0	12.0	9.0	12.0	14.0	7.0	8.0	10.0	7.0	8.0	10.0		
		30	1.5	5.0	5.0	1.5	30	3.0	2.0	3.0	4.5	3.0	4.0	5.0	5.0	6.0	7.0	6.0	7.0	8.0	10.0	5.5	6.5	7.0	7.0	9.0	11.0
			1.3	4.6		10.0		2.0	3.0	4.5	4.0	4.5	6.0	6.0	7.5	10.0	7.0	9.0	11.0	7.0	9.0	10.0	7.0	9.0	12.0		
			1.6	5.8		20		2.0	3.0	4.0	4.5	6.0	8.0	7.0	9.0	12.0	8.0	10.0	12.0	8.0	10.0	12.0	8.0	9.0	11.0		
		40	2.1	10.0	10.0	2.1	40	3.0	2.5	3.5	6.0	3.5	4.5	7.0	5.0	6.0	8.0	6.0	8.0	10.0	6.0	8.0	9.0	7.0	9.0	11.0	
			2.5	15.0		10.0		2.0	3.0	5.0	4.0	5.0	7.5	5.0	7.0	9.0	7.0	9.0	11.0	6.0	8.0	9.5	7.0	9.0	11.0		
			2.9	20		20		2.0	3.0	4.5	4.0	5.5	8.0	6.0	8.0	10.0	8.0	9.0	11.0	6.0	8.5	10.5	8.0	10.0	12.0		
SUV67	Fluid Cap VMF2850 + Air Cap VMA67255-60	10.0	.58	2.0	1.0	1.26	10.0	3.0	2.0	3.0	5.0	7.0	9.0	14.0	9.0	12.0	15.0	9.0	10.0	12.0	-	-	-	-	-		
			.73	2.6		10.0		-	-	-	8.5	11.0	15.0	12.0	15.0	21	15.0	18.0	19.0	-	-	-	-	-	-		
			.84	3.1		20		-	-	-	-	-	-	10.0	12.0	16.0	14.0	18.0	23	15.0	19.0	23	-	-	-		
		20	2.2	3.0	3.0	2.2	20	3.0	2.5	3.0	4.5	6.0	7.0	9.0	7.5	9.0	11.0	8.0	10.0	13.0	5.5	6.5	8.0	8.0	9.0	12.0	
			2.8	5.0		10.0		-	-	-	6.0	8.0	11.0	9.0	11.0	15.0	12.0	15.0	19.0	11.0	12.0	14.0	11.0	12.0	12.0		
			4.0	10.0		20		-	-	-	7.0	9.0	12.0	10.0	12.0	17.0	13.0	17.0	20	14.0	17.0	20	17.0	20	23		
		30	4.9	15.0	15.0	4.9	30	3.0	2.5	3.0	4.5	5.0	6.0	8.0	6.0	8.0	9.0	8.0	10.0	13.0	5.0	5.5	6.5	7.0	8.0	10.0	
			5.6	20		10.0		-	-	-	5.0	7.0	10.0	8.0	11.0	15.0	11.0	14.0	19.0	9.0	11.0	12.0	9.0	10.0	12.0		
			5.6	20		20		-	-	-	-	-	-	8.0	11.0	14.0	11.0	14.0	19.0	12.0	16.0	19.0	16.0	20	22		
		SUV113A	Fluid Cap VMF3578 + Air Cap VMA113289-60	10.0	1.6	3.9	1.0	2.1	10.0	3.0	-	-	-	8.0	10.5	14.0	10.0	13.0	17.0	8.0	10.0	13.0	-	-	-	-	-
					2.0	4.8		10.0		-	-	-	10.0	12.0	16.0	12.0	14.0	18.0	-	-	-	-	-	-	-	-	
					2.4	5.8		20		-	-	-	12.0	14.0	16.5	12.0	16.5	22	-	-	-	-	-	-	-	-	-
20	3.6			3.0	3.0	3.6	20	3.0	1.5	2.0	3.0	5.0	7.0	10.0	8.0	11.0	14.0	8.5	12.0	14.0	7.0	8.5	11.0	5.5	7.0	9.0	
	3.3			7.6		10.0		-	-	-	7.0	9.0	12.0	9.0	12.0	15.0	-	-	-	-	-	-	-	-			
	3.6			9.3		20		-	-	-	7.0	9.0	12.0	10.5	13.5	16.5	-	-	-	-	-	-	-	-			
30	4.7			5.0	5.0	4.7	30	3.0	2.0	2.5	3.5	4.0	5.0	7.0	6.0	8.0	11.0	8.0	11.0	14.0	8.0	10.5	13.0	7.5	9.0	11.0	
	6.6			10.0		10.0		-	-	-	5.0	7.0	10.0	6.5	10.0	13.0	9.0	12.0	15.5	9.0	11.0	12.0	-	-	-		
	8.0			15.0		20		-	-	-	4.5	6.0	8.0	6.5	10.0	13.0	10.0	14.0	16.0	-	-	-	-	-			
40	9.4			20	20	9.4	40	3.0	2.0	2.5	4.0	4.0	5.0	6.0	5.5	7.5	11.0	8.0	10.5	14.0	8.0	10.0	13.0	7.5	8.5	12.0	
	15.9			15.0		10.0		2.5	3.5	5.56	4.0	5.0	7.5	6.0	8.0	10.0	9.0	11.5	16.0	8.0	11.0	14.0	8.0	8.5	12.0		
	17.6			20		20		2.0	3.0	4.0	4.5	6.0	8.5	6.5	9.0	12.0	10.0	14.0	18.5	10.0	13.5	18.0	8.5	10.5	14.5		
60	9.4	20	20	9.4	60	3.0	2.0	2.5	3.0	2.0	4.0	5.0	5.0	6.5	8.0	8.0	10.0	12.0	7.5	9.5	14.0	7.5	9.5	12.0			
	15.9	15.0		10.0		2.5	3.0	4.5	4.0	4.5	6.0	5.5	7.0	9.5	8.0	10.0	13.0	10.0	12.0	15.0	9.0	12.0	15.0				
	17.6	20		20		2.5	3.0	5.0	4.0	4.5	7.5	5.5	7.5	9.5	8.5	11.0	10.0	10.0	12.5	18.0	9.0	12.0	15.0				

*At the stated pressure in psi.

Anti-bearding set-ups are available to reduce nozzle build-up and maintenance time for select external mix air atomizing nozzles. For more information, call 1.800.95.SPRAY.



**PERFORMANCE DATA:
VMAU PRESSURE SPRAY SET-UPS | EXTERNAL MIX | VARIABLE SPRAY**

Spray Set-up No.	Spray Set-up Consists of Fluid and Air Cap Combination	Air Capacity*			Liquid Capacity*		Spray Coverage (in.) at Indicated Distance from Nozzle Fan Air Pressure																								
		Press.	Capacity		Press.	Cap. gph	Atom. Air Press.	Water Press.	0			5			10			20			30			40							
			Atomizing Air scfm	Fan Air scfm					A	B	C	A	B	C	A	B	C	A	B	C	A	B	C	A	B	C					
SUVM113	Fluid Cap VMF4078 + Air Cap VMA113289-60	10.0	1.6	3.9	1.0	2.9	10.0	3.0	2.0	2.5	4.0	7.0	7.5	17.0	11.0	15.0	18.0	10.0	13.5	15.0	-	-	-	-	-	-					
									6.0	-	-	-	8.0	11.5	17.0	12.0	17.0	22	-	-	-	-	-	-	-	-	-	-	-	-	
									10.0	-	-	-	9.0	13.0	18.0	12.0	17.0	23	-	-	-	-	-	-	-	-	-	-	-	-	-
		15.0	2.0	4.8	3.0	4.9	20	3.0	6.0	2.0	3.0	5.0	6.5	9.0	11.0	9.0	13.0	18.0	10.0	13.0	16.5	-	-	-	-	-	-				
										6.0	2.0	4.0	5.0	7.0	9.0	12.0	9.5	12.0	17.0	14.0	15.0	18.5	-	-	-	-	-	-	-	-	
										10.0	-	-	-	6.5	10.5	14.0	11.0	14.0	18.5	16.0	19.0	20	-	-	-	-	-	-	-	-	-
		20	2.4	5.8	5.0	6.4	30	6.0	3.0	2.0	2.5	4.0	5.0	7.0	11.0	7.0	11.0	13.5	9.0	12.0	17.0	8.0	11.0	13.0	-	-	-				
										6.0	1.5	2.5	3.0	5.0	7.5	10.0	8.0	10.0	14.5	11.0	13.5	16.0	10.0	12.0	15.5	7.5	10.0	14.0	-	-	-
										10.0	-	-	-	5.5	8.0	11.0	8.0	10.5	14.0	11.5	15.0	20.5	12.0	15.0	18.0	9.5	12.0	17.0	-	-	-
		30	3.3	7.6	10.0	9.0	40	3.0	3.0	1.5	2.5	4.5	4.0	6.0	8.0	6.5	8.5	12.0	9.0	12.0	16.0	8.5	11.5	15.0	8.5	11.0	14.5				
										6.0	1.5	2.5	4.0	4.5	6.0	8.0	7.0	9.0	12.5	10.0	13.0	17.0	10.5	12.0	16.0	8.5	11.0	15.0	-	-	-
										10.0	2.0	3.0	8.0	4.5	6.5	7.5	7.0	10.0	14.5	10.0	14.0	19.0	11.0	13.0	17.0	10.0	12.0	19.0	-	-	-
		40	3.6	9.3	15.0	11.0	60	6.0	3.0	2.0	3.0	4.0	3.5	5.0	7.0	6.0	7.5	10.0	8.0	11.0	14.0	9.0	11.0	15.0	8.0	10.5	14.0				
										6.0	2.0	3.0	4.0	5.0	7.5	6.0	8.0	10.5	12.0	9.0	12.5	15.5	9.0	12.5	18.0	9.5	11.5	16.5	-	-	-
										10.0	2.0	3.0	4.0	3.5	5.0	8.0	6.0	8.0	13.0	8.5	10.5	16.5	9.5	13.0	16.0	9.5	12.5	16.5	-	-	-
		50	4.5	11.0	20	12.8	60	6.0	3.0	2.0	3.0	4.0	3.5	5.0	7.0	6.0	7.5	10.0	8.0	11.0	14.0	9.0	11.0	15.0	8.0	10.5	14.0				
										6.0	2.0	3.0	4.0	5.0	7.5	6.0	8.0	10.5	12.0	9.0	12.5	15.5	9.0	12.5	18.0	9.5	11.5	16.5	-	-	-
										10.0	2.0	3.0	4.0	3.5	5.0	8.0	6.0	8.0	13.0	8.5	10.5	16.5	9.5	13.0	16.0	9.5	12.5	16.5	-	-	-
60	5.2	12.7	15.0	11.0	60	6.0	3.0	2.0	3.0	4.0	3.5	5.0	7.0	6.0	7.5	10.0	8.0	11.0	14.0	9.0	11.0	15.0	8.0	10.5	14.0						
								6.0	2.0	3.0	4.0	5.0	7.5	6.0	8.0	10.5	12.0	9.0	12.5	15.5	9.0	12.5	18.0	9.5	11.5	16.5	-	-	-		
								10.0	2.0	3.0	4.0	3.5	5.0	8.0	6.0	8.0	13.0	8.5	10.5	16.5	9.5	13.0	16.0	9.5	12.5	16.5	-	-	-		
70	5.9	14.4	15.0	11.0	60	6.0	3.0	2.0	3.0	4.0	3.5	5.0	7.0	6.0	7.5	10.0	8.0	11.0	14.0	9.0	11.0	15.0	8.0	10.5	14.0						
								6.0	2.0	3.0	4.0	5.0	7.5	6.0	8.0	10.5	12.0	9.0	12.5	15.5	9.0	12.5	18.0	9.5	11.5	16.5	-	-	-		
								10.0	2.0	3.0	4.0	3.5	5.0	8.0	6.0	8.0	13.0	8.5	10.5	16.5	9.5	13.0	16.0	9.5	12.5	16.5	-	-	-		
80	6.5	15.9	15.0	11.0	60	6.0	3.0	2.0	3.0	4.0	3.5	5.0	7.0	6.0	7.5	10.0	8.0	11.0	14.0	9.0	11.0	15.0	8.0	10.5	14.0						
								6.0	2.0	3.0	4.0	5.0	7.5	6.0	8.0	10.5	12.0	9.0	12.5	15.5	9.0	12.5	18.0	9.5	11.5	16.5	-	-	-		
								10.0	2.0	3.0	4.0	3.5	5.0	8.0	6.0	8.0	13.0	8.5	10.5	16.5	9.5	13.0	16.0	9.5	12.5	16.5	-	-	-		
90	7.2	17.6	20	12.8	60	6.0	3.0	2.0	3.0	4.0	3.5	5.0	7.0	6.0	7.5	10.0	8.0	11.0	14.0	9.0	11.0	15.0	8.0	10.5	14.0						
								6.0	2.0	3.0	4.0	5.0	7.5	6.0	8.0	10.5	12.0	9.0	12.5	15.5	9.0	12.5	18.0	9.5	11.5	16.5	-	-	-		
								10.0	2.0	3.0	4.0	3.5	5.0	8.0	6.0	8.0	13.0	8.5	10.5	16.5	9.5	13.0	16.0	9.5	12.5	16.5	-	-	-		

Spray Set-up No.	Spray Set-up Consists of Fluid and Air Cap Combination	Air Capacity*			Liquid Capacity*		Spray Coverage (in.) at Indicated Distance from Nozzle Fan Air Pressure																								
		Press.	Capacity		Press.	Cap. gph	Atom. Air Press.	Water Press.	0			5			10			15			20			25							
			Atomizing Air scfm	Fan Air scfm					A	B	C	A	B	C	A	B	C	A	B	C	A	B	C	A	B	C					
SUVM128	Fluid Cap VMF60100 + Air Cap VMA1282100-60	10.0	1.8	4.9	1.0	6.6	10.0	1.0	-	-	-	10.0	13.5	21	13.0	16.0	22	12.0	16.0	21	-	-	-	-	-						
									3.0	-	-	-	9.5	12.5	19.0	14.0	18.0	24	12.5	17.0	24	12.0	16.0	20	-	-	-	-	-		
									6.0	-	-	-	10.0	13.0	20	14.0	19.0	26	16.0	22	30	18.0	24.5	34	19.0	24	33	-	-	-	
		15.0	2.2	5.9	3.0	10.8	20	1.0	1.0	-	-	-	6.0	8.5	13.0	8.0	11.0	17.5	9.5	13.0	17.5	8.0	12.0	14.0	8.0	10.5	12.0				
										3.0	-	-	-	7.0	10.0	14.5	9.0	12.5	18.0	10.0	14.0	20	9.5	13.0	18.5	10.0	13.0	16.0	-	-	-
										6.0	-	-	-	7.5	10.5	14.5	10.0	14.0	19.5	12.0	17.5	24	11.0	17.5	26	12.0	18.0	27	-	-	-
		20	2.6	7.0	5.0	13.8	30	1.0	1.5	3.0	4.5	5.0	7.0	9.5	7.0	10.0	14.0	9.0	11.0	14.0	10.0	14.0	17.0	9.5	12.0	16.0					
										3.0	2.0	3.0	5.0	5.5	8.0	13.5	8.0	11.0	15.0	9.5	13.0	19.0	10.0	14.0	19.0	10.0	13.0	16.5	-	-	-
										6.0	1.0	3.0	5.0	4.5	6.0	9.5	8.0	11.0	16.0	9.5	13.0	19.0	10.0	14.5	21.5	12.0	16.0	22	-	-	-
		30	3.4	9.1	10.0	19.8	40	1.0	2.0	3.0	5.5	5.0	6.0	9.0	6.0	9.0	13.0	8.0	11.0	15.5	8.5	11.5	14.5	9.0	13.0	17.0					
										3.0	2.5	3.0	5.5	5.0	7.0	10.0	6.5	9.5	14.0	8.0	12.0	18.0	10.0	13.0	19.0	10.0	13.5	19.0	-	-	-
										6.0	2.0	3.0	4.0	5.0	7.0	10.0	6.0	10.0	15.0	9.0	13.0	18.0	10.0	14.0	20	11.0	14.5	22	-	-	-
		40	4.3	11.2	15.0	24	60	1.0	3.0	4.0	6.0	4.5	6.0	9.0	5.5	8.0	12.0	6.5	10.0	14.0	8.5	9.0	14.5	8.5	12.0	16.0					
										3.0	3.0	4.0	4.5	6.5	9.5	6.0	8.5	12.0	7.0	10.0	14.0	9.0	11.0	16.0	9.0	11.0	16.0	9.0	12.0	16.5	
										6.0	2.5	3.5	4.0	4.0	5.5	7.5	5.0	7.0	11.0	6.5	9.0	13.5	8.0	11.0	17.0	9.0	11.0	16.0	9.0	12.0	18.0
		50	5.0	13.3	20	28.2	60	1.0	3.0	4.0	6.0	4.5	6.0	9.0	5.5	8.0	12.0	6.5	10.0	14.0	8.5	9.0	14.5	8.5	12.0	16.0					
										3.0	3.0	4.0	4.5	6.5	9.5	6.0	8.5	12.0	7.0	10.0	14.0	9.0	11.0	16.0	9.0	11.0	16.0	9.0	12.0	16.5	
										6.0	2.5	3.5	4.0	4.0	5.5	7.5	5.0	7.0	11.0	6.5	9.0	13.5	8.0	11.0	17.0	9.0	11.0	16.0	9.0	12.0	18.0
60	5.8	15.3	15.0	24	60	1.0	3.0	4.0	6.0	4.5	6.0	9.0	5.5	8.0	12.0	6.5	10.0	14.0	8.5	9.0	14.5	8.5	12.0	16.0							
								3.0	3.0	4.0	4.5	6.5	9.5	6.0	8.5	12.0	7.0	10.0	14.0	9.0	11.0	16.0	9.0	11.0	16.0	9.0	12.0	16.5			
								6.0	2.5	3.5	4.0	4.0	5.5	7.5	5.0	7.0	11.0	6.5	9.0	13.5	8.0	11.0	17.0	9.0	11.0	16.0	9.0	12.0	18.0		
70	6.6	17.2	15.0	24	60	1.0	3.0	4.0	6.0	4.5	6.0	9.0	5.5	8.0	12.0	6.5	10.0	14.0	8.5	9.0	14.5	8.5	12.0	16.0							
								3.0	3.0	4.0	4.5	6.5	9.5	6.0	8.5	12.0	7.0	10.0	14.0	9.0	11.0	16.0	9.0	11.0	16.0	9.0	12.0	16.5			
								6.0	2.5	3.5	4.0	4.0	5.5	7.5	5.0	7.0	11.0	6.5	9.0	13.5	8.0	11.0	17.0	9.0	11.0	16.0	9.0	12.0	18.0		
80	7.4	19.2	15.0	24	60	1.0	3.0	4.0	6.0	4.5	6.0	9.0	5.5	8.0	12.0	6.5	10.0	14.0	8.5	9.0	14.5	8.5	12.0	16.0							
								3.0	3.0	4.0	4.5	6.5	9.5	6.0	8.5	12.0	7.0	10.0	14.0	9.0	11.0	16.0	9.0	11.0	16.0						

NUMBERING SYSTEM FOR AIR CAPS AND FLUID CAPS

The drawings below illustrate the measurements used in the Spray Performance Data charts.

**AIR CAPS
PRESSURE SET-UPS (INTERNAL MIX)**

Round Spray Pattern

Example: Air Cap No. PA67147

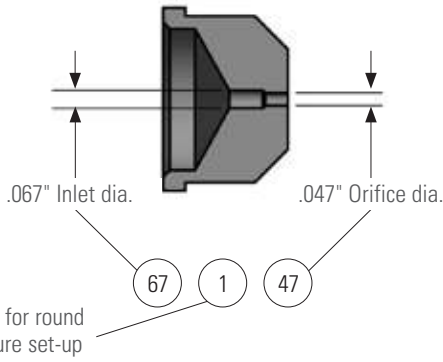

Wide Angle Round Spray Pattern

Example: Air Cap No. PA67-6-20-70

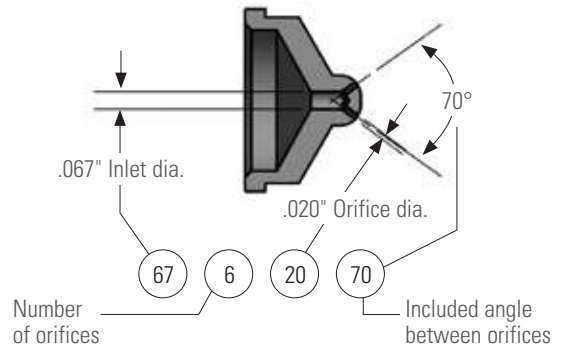

Flat Spray Pattern

Example: Air Cap No. PA73320

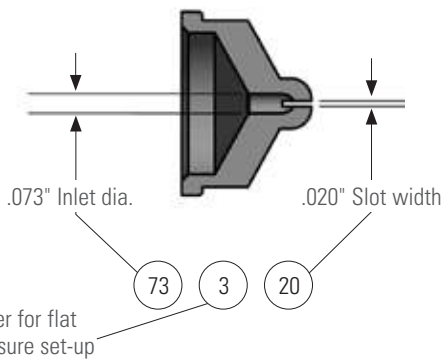

Dimensions shown are nominal and subject to manufacturing tolerances.

PLACING YOUR ORDER

**Call 1.800.95.SPRAY for application assistance
or to place an order.**

AIR CAPS

SIPHON/GRAVITY FEED SET-UPS (EXTERNAL MIX)

Round Spray Pattern

Example: Air Cap No. PA64

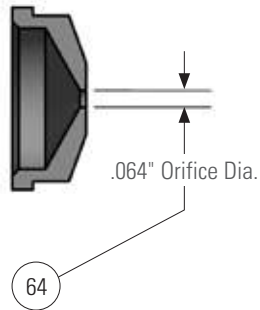

Flat Round Spray Pattern

Example: Air Cap No. PA73420

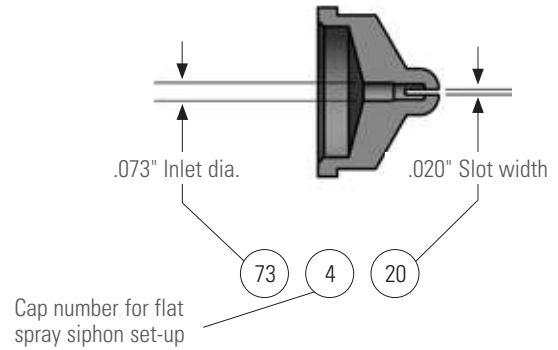

AIR CAPS

PRESSURE SET-UPS (EXTERNAL MIX)

Flat Spray Pattern

Example: Air Cap No. PA200278-45

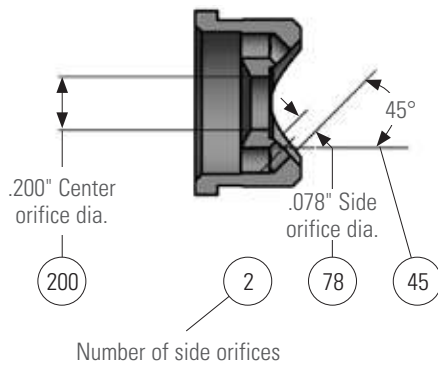

FLUID CAP

FOR USE WITH ALL SET-UPS

Fluid Cap

Example: Fluid Cap No. PF2850

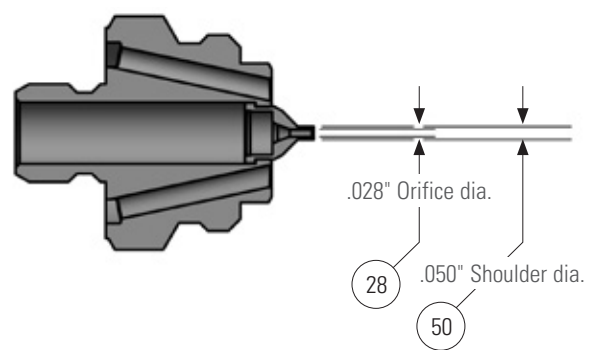

Dimensions shown are nominal and subject to manufacturing tolerances.

AIR ATOMIZING SET-UP COMPATIBILITY

Use the chart that follows to determine which spray set-ups can be used with our atomizing nozzles. The chart also includes the part number for the air cap and fluid cap that are required for each spray set-up.

Set-up No.	Spray Pattern	Fluid Cap No.	Air Cap No.
SU11	Round	PF2050	PA67147
SU12A	Round	PF2050	PA73160
SU12	Round	PF2850	PA73160
SU22B	Round	PF40100	PA1401110
SU22	Round	PF60100	PA1401110
SU42	Round	PF100150	PA1891125
SU16	Wide Angle Round	PF2050	PA67-6-20-70
SU26B	Wide Angle Round	PF40100	PA140-6-37-70
SU26	Wide Angle Round	PF60100	PA140-6-37-70
SU29	Wide Angle Round	PF60100	PA140-6-52-70
SU30	Wide Angle Round	PF40100	PA120-6-35-60
SU46	Wide Angle Round	PF100150	PA189-6-62-70
SU340C	360° Circular	PF60150	PA189-6-62-160HC
SU13A	Flat	PF2050	PA73328
SU13	Flat	PF2850	PA73328
SUN13	Flat	PF2850	PA73335
SU14	Flat	PF2850	PA73320
SUN23	Flat	PF60100	PA125340
SU23B	Flat	PF40100	PA125328
SU23	Flat	PF60100	PA125328
SU43	Flat	PF100150	PA189351
SU240E	Deflected Flat	PF28150	PA189110-75
SUE15B	Flat	PF1650	PA67228-45

Set-up No.	Spray Pattern	Fluid Cap No.	Air Cap No.
SUE18B	Flat	PF1650	PA62240-60
SUE15A	Flat	PF2050	PA67228-45
SUE18A	Flat	PF2050	PA62240-60
SUE15	Flat	PF2850	PA67228-45
SUE18	Flat	PF2850	PA62240-60
SUE25B	Flat	PF35100	PA134255-45
SUE28B	Flat	PF35100	PA122281-60
SUE25A	Flat	PF40100	PA134255-45
SUE28A	Flat	PF40100	PA122281-60
SUE28	Flat	PF60100	PA122281-60
SUE25	Flat	PF60100	PA134255-45
SUE45B	Flat	PF60150	PA200278-45
SUE45A	Flat	PF80150	PA200278-45
SUE45	Flat	PF100150	PA200278-45
SUF1	Flat	PF2850	PA73420
SUF2C	Flat	PF35100	PA120432
SUF3B	Flat	PF40100	PA122435
SUF4B	Flat	PF40100	PA122440
SU1A	Round	PF1650	PA64
SU1	Round	PF2050	PA64
SU2A	Round	PF2050	PA70
SU2	Round	PF2850	PA70
SU4	Round	PF60100	PA120



Set-up No.	Spray Pattern	Fluid Cap No.	Air Cap No.
SU5	Round	PF100150	PA180
D-SU1A-W D-SU1A-W-CO	Wide Angle Round	Fluid caps and air caps not sold separately.	
D-SU1-W D-SU1-W-CO	Wide Angle Round		
D-SU2A-W D-SU2A-W-CO	Wide Angle Round		
D-SU2-W D-SU2-W-CO	Wide Angle Round		
D-SU4-W D-SU4-W-CO	Wide Angle Round		
D-SU5-W D-SU5-W-CO	Wide Angle Round		
SUJ11	Round		
SUJ12A	Round	PFJ2050	PAJ73160
SUJ12	Round	PFJ2850	PAJ73160
SUJ22B	Round	PFJ40100	PAJ1401110
SUJ22	Round	PFJ60100	PAJ1401110
SUJ340C	360° Circular	PFJ60100	PAJ150-6-62-160HC
SUJ16	Wide Angle Round	PFJ2050	PAJ67-6-20-70
SUJ26B	Wide Angle Round	PFJ40100	PAJ140-6-37-70
SUJ26	Wide Angle Round	PFJ60100	PAJ140-6-37-70
SUJ29	Wide Angle Round	PFJ60100	PAJ140-6-52-70
SUJ30	Wide Angle Round	PFJ40100	PAJ120-6-35-60
SUJ13A	Flat	PFJ2050	PAJ73328
SUJ13	Flat	PFJ2850	PAJ73328
SUJ14	Flat	PFJ2850	PAJ73320
SUJ23B	Flat	PFJ40100	PAJ125328
SUJ23	Flat	PFJ60100	PAJ125328
SUJE416-50	Flat	PFJ1650	PAJ105-50
SUJE417-50	Flat	PFJ2050	PAJ105-50

Set-up No.	Spray Pattern	Fluid Cap No.	Air Cap No.
SUJE418-50	Flat	PFJ2850	PAJ105-50
SUJE420-50	Flat	PFJ40100	PAJ135-50
SUJE416-65	Flat	PFJ1650	PAJ080-65
SUJE417-65	Flat	PFJ2050	PAJ080-65
SUJE418-65	Flat	PFJ2850	PAJ080-65
SUJE420-65	Flat	PFJ40100	PAJ125-65
SUJE421-65	Flat	PFJ60100	PAJ-125-65
SUJE416-90	Flat	PFJ1650	PAJ075-90
SUJE417-90	Flat	PFJ2050	PAJ075-90
SUJE418-90	Flat	PFJ2850	PAJ075-90
SUJE420-90	Flat	PFJ40100	PAJ115-90
SUJE421-90	Flat	PFJ60100	PAJ115-90
SUJ1A	Round	PFJ1650	PAJ64
SUJ1	Round	PFJ2050	PAJ64
SUJ2A	Round	PFJ2050	PAJ70
SUJ2	Round	PFJ2850	PAJ70
SUJ3	Round	PFJ2850	PAJ64-5
SUJ4B	Round	PFJ40100	PAJ120
SUJ4	Round	PFJ60100	PAJ120
SUJF1	Flat	PFJ2850	PAJ73420
SUJF2C	Flat	PFJ35100	PAJ120432
SUJF3B	Flat	PFJ40100	PAJ122435
SUJF4B	Flat	PFJ40100	PAJ122440
SU70	Round	PF250375	PA437
SU75	Flat	PF250375	PA4533102



Set-up No.	Spray Pattern	Fluid Cap No.	Air Cap No.
SU380C	360° Circular	PF251376	PA469-6-130-160HC
SU85	Flat	PF251376	PA4693102
SU77	Wide Angle Round	PF250375	PA422-6-73-70
SU78	Wide Angle Round	PF250375	PA422-6-94-70
SU79	Wide Angle Round	PF250375	PA469-6-125-70
SU89	Wide Angle Round	PF251376	PA469-6-130-70
SU72	Round	PF250375	PA4221250
SU82	Round	PF251376	PA4691312
SUE75	Flat	PF250375	PA14356
SU159	Wide Angle Round	PF4371000	PA1109-6-224-70
SU152	Round	PF4371000	PA11091547
SU172	Round	PF6251000	PA11251625
SU155	Flat	PF4371000	PA11093187
SUE175B	Flat	PF625780	PA12116
SU170	Round	PF6251000	PA1125
SUQR-220B	Round	PFQ40	PAQR95
SUQW-260B	Wide Angle Round	PFQ30	PAQW37-60
SUQW-260	Wide Angle Round	PFQ60	PAQW37-60
SUQW-290	Wide Angle Round	PFQ60	PAQW52-60
SUQF-130	Flat	PFQ20	PAQF28
SUQF-N130	Flat	PFQ30	PAQF28
SUQF-230B	Flat	PFQ30	PAQF35
SUQF-230	Flat	PFQ40	PAQF40
SUQR-200	Round	PFQ5028	PAQR070
SUQR-300	Round	PFQ10060	PAQR120
SUQF-200C	Flat	PFQ10035	PAQF450121
SUQF-300B	Flat	PFQ10040	PAQF450121

Set-up No.	Spray Pattern	Fluid Cap No.	Air Cap No.
SUQF-300	Flat	PFQ10060	PAQF450121
SUVM67B	Variable	VMF1650	VMA67255-60
SUVM67A	Variable	VMF2050	VMA67255-60
SUVM67	Variable	VMF2850	VMA67255-60
SUVM113A	Variable	VMF3578	VMA113289-60
SUVM113	Variable	VMF4078	VMA113289-60
SUVM128	Variable	VMF60100	VMA1282100-60
SUVM152	Variable	VMF80125	VMA1522110-60
SUV67B	Variable	VF1650	VA67255-60
SUV67A	Variable	VF2050	VA67255-60
SUV67	Variable	VF2850	VA67255-60
SUV113A	Variable	VF3578	VA113293-60
SUV113	Variable	VF4078	VA113293-60
SUV128	Variable	VF60100	VA1282125-60
SUV152	Variable	VF80125	VA1522125-60
SUVXE1A	Flat	PFX16	PAVX140A
SUVXE2C	Flat	PFX16	PAVX156A
SUVXE1	Flat	PFX20	PAVX140A
SUVXE2B	Flat	PFX20	PAVX156A
SUVXE2A	Flat	PFX28	PAVX156A
SUVXE3B	Flat	PFX28	PAVX180A
SUVXE2	Flat	PFX40	PAVX156A
SUVXE3A	Flat	PFX40	PAVX180A
SUVXE3	Flat	PFX60	PAVX180A
SUVXE4B	Flat	PFX60	PAVX200A
SUVXE4A	Flat	PFX80	PAVX200A
SUVXE4	Flat	PFX100	PAVX200A

